

Harmonic Filter AHF 005/010

A microscopic view of a filter material, showing a regular grid of dark, oval-shaped pores on a light-colored background.

# Instruction Manual



**Drives Solutions**

[www.danfoss.com/drives](http://www.danfoss.com/drives)

**■ Contents**

|   |    |
|---|----|
| <b>Safety</b> .....                                       | 2  |
| Warnings .....  | 2  |
| Symbols used in this manual .....                         | 2  |
| Operator's safety .....                                   | 2  |
| Avoid filter module damage .....                          | 2  |
| DC-link resonance .....                                   | 2  |
| <br>  |    |
| <b>Description</b> .....                                  | 3  |
| Description .....   | 3  |
| Ordering numbers, 380 - 415 V .....                       | 4  |
| Ordering numbers, 440 - 480 V .....                       | 5  |
| Calculation of the exact filter size needed .....         | 5  |
| <br>  |    |
| <b>Specifications</b> .....                               | 6  |
| General technical data .....                              | 6  |
| Environmental data .....                                  | 6  |
| Dimensions/weight .....                                   | 7  |
| Dimension diagrams .....                                  | 8  |
| <br>  |    |
| <b>Installation</b> .....                                 | 10 |
| Mechanical installation .....                             | 10 |
| Ventilation .....   | 10 |
| Power wiring .....  | 10 |
| Over temperature contactor .....                          | 11 |
| Power wiring size (copper) .....                          | 12 |
| Operation on different mains type .....                   | 12 |
| Typical installation in a panel or other enclosures ..... | 13 |
| <br>  |    |
| <b>Commissioning</b> .....                                | 14 |
| Commissioning .....                                       | 14 |
| <br>  |    |
| <b>Appendix: Safety and application notes for</b> .....   | 15 |
| 1. General .....  | 15 |
| 2. Application as directed .....                          | 15 |
| 3. Transport, Storage .....                               | 15 |
| 4. Installation .....                                     | 15 |
| 5. Electrical Installation .....                          | 15 |
| 6. Operation .....  | 15 |
| 7. Maintenance and service .....                          | 16 |

### ■ Warnings



The Danfoss harmonic filter AHF 005 and AHF 010 contain dangerous voltages when connected to line voltages. Only a competent electrician should carry out the electrical installation. Improper installation of the filter module or the connected frequency converter may cause equipment failure, serious injury or death. Follow this manual and National Electrical Codes and local safety codes. Operation of the harmonic filter is only allowed with a closed cover of the housing!

### ■ Symbols used in this manual

When you read this manual you will come across different symbols that require special attention. The symbols used are the following:



Warning of hazardous electrical voltage



Warning of a general danger



**NB!:**

This note designates general, useful notes. If you observe it, handling of the filter module / drive system is made easier.

### ■ Operator's safety



After mains disconnections, the power terminals X1.1, X1.2 and X1.3 remain live for minimum 15 minutes.



The filter modules have to be installed in a way, that they fulfil their function and don't expose persons to danger. They have to be mounted correctly and used in accordance with their purpose.

### ■ Avoid filter module damage

1. The filter modules are to be used only with Danfoss frequency converters. The usage with other electrical loads is not permitted and may damage the devices.
2. Don't use the drive system (frequency converter, motor load and filter module) if the equipment has been damaged.
3. Modifications of the filter modules are not allowed.

### ■ DC-link resonance

To prevent resonance's in the DC-link, it is recommended to disable the dynamic DC link compensation.

#### 483 Dynamic DC link compensation (DC LINK COMP.)

##### Value:

|     |     |
|-----|-----|
| Off | [0] |
| ★On | [1] |

##### Function:

The VLT 5000, 6000 and 8000 series include a feature, which ensures that the output voltage is independent of any voltage fluctuation in the DC link, e.g. caused by fast fluctuation in the mains supply voltage. The benefit is a very steady torque on motor shaft (low torque ripple) under most mains conditions.

##### Description of choice:

In some cases this very dynamic compensation can cause resonance's in the DC link and should then be disabled. Typical cases are where a line choke or a passive harmonic filter (e.g. filters AHF005/010) is mounted in the mains supply to the frequency converter to suppress harmonics. Can also occur on mains with low short circuit ratio.

### ■ Description

The Danfoss harmonic filters AHF 005 and AHF 010 are ensuring near sinusoidal line current minimising the harmonic current emission into the mains supply. The Danfoss AHF 005 and AHF 010 are advanced harmonic filters not to be compared with traditional harmonic trap filters. The Danfoss harmonic filters have been specially designed to match all the Danfoss frequency converters. The filters AHF 010 and AHF 005 are available in two voltage ratings.

- 380 - 415 V AC
- 440 - 480 V AC

The Danfoss AHF 010 and AHF 005 have the following characteristics:

- Small compact housing that fits into a panel
- Easy to use in retrofit applications
- AHF 010 reduces the total harmonic current distortion to 10%\*
- AHF 005 reduces the total harmonic current distortion to 5%\*
- Current rating from 10A - 324A
- For higher power modules can be paralleled
- One filter module can be used for several frequency converters
- High efficiency (> 0.98)
- User-friendly commissioning - no adjustment necessary
- No routine maintenance required

\* THiD of 10% or 5% will be achieved when the following conditions are met:

- THvD of the system without the drive operating is less than 2%
- Filter is operating at nominal load

If these conditions are not fulfilled, a significant reduction of the harmonic components can still be achieved, but the rated THiD values may not be achieved.

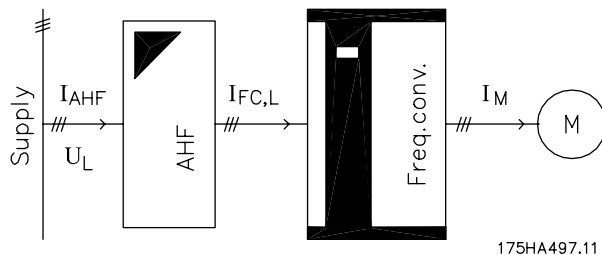

**Principle connection diagram of the Danfoss harmonic filter.**

Legends (as used throughout this manual):

|              |  |
|--------------|--|
| $U_L$ :      | Line voltage                             |
| $I_{AHF}$ :  | Input current of the filter AHF          |
| $I_{FC,L}$ : | Input current to the frequency converter |
| $I_M$ :      | Motor current                            |

**■ Ordering numbers, 380 - 415 V**
**AHF 005 and AHF 010, 380V - 415V, 50Hz**

| I <sub>AHF,N</sub>   | Typical Motor Used [kW] | Danfoss ordering number |          | Typical Danfoss frequency converter series |               |               |
|--|-------------------------|-------------------------|----------|--|---------------|---------------|
|  |                         | AHF 005                 | AHF 010  | VLT 5000                                   | VLT 6000 HVAC | VLT 8000 AQUA |
| 10 A   | 4, 5.5                  | 175G6600                | 175G6622 | 5006, 5008                                 | 6006, 6008    | 8006, 8008    |
| 19 A   | 7.5                     | 175G6601                | 175G6623 | 5011                                       | 6011, 6016    | 8011, 8016    |
| 26 A   | 11                      | 175G6602                | 175G6624 | 5016                                       | 6022          | 8022          |
| 35 A   | 15, 18.5                | 175G6603                | 175G6625 | 5022, 5027                                 | 6027          | 8027          |
| 43 A   | 22                      | 175G6604                | 175G6626 | 5032                                       | 6032          | 8032          |
| 72 A   | 30, 37                  | 175G6605                | 175G6627 | 5042, 5072                                 | 6042, 6052    | 8042, 8052    |
| 101 A  | 45, 55                  | 175G6606                | 175G6628 | 5062, 5072                                 | 6062, 6072    | 8062, 8072    |
| 144 A  | 75                      | 175G6607                | 175G6629 | 5102                                       | 6102          | 8102          |
| 180 A  | 90                      | 175G6608                | 175G6630 | 5125                                       | 6122          | 8122          |
| 217 A  | 110                     | 175G6609                | 175G6631 | 5150                                       | 6150          | 8150          |
| 289 A  | 132, 160                | 175G6610                | 175G6632 | 5200, 5250                                 | 6175, 6225    | 8200, 8250    |
| 324 A  |                         | 175G6611                | 175G6633 |  |               |               |
| Higher ratings can be achieved by paralleling the filter units |                         |                         |          |  |               |               |
| 360 A  | 200                     | Two 180 A units         |          | 5300                                       | 6275          | 8300          |
| 434 A  | 250                     | Two 217 A units         |          | 5350                                       | 6350          | 8350          |
| 578 A  | 315                     | Two 289 A units         |          | 5450                                       | 6400          | 8450          |
| 613 A  | 355                     | 289 A and 324 A units   |          | 5500                                       | 6500          | 8500          |

\* Please note that the matching of the typical Danfoss frequency converter and filter is pre-calculated based on 400V and assuming typical motor load (4 or 2 pole motor). VLT 5000 series is based on a max. 160 % torque application, while VLT 6000 and 8000 series are based on a max. 110% torque application. The pre-calculated filter current may be different than the input current ratings of VLT 5000, VLT 6000 and VLT 8000 series as stated in the respective operating instructions, as these numbers are based on different operating conditions.

---

■ Ordering numbers, 440 - 480 V

| I <sub>AHF,N</sub>   | Typical Motor Used [HP] | Danfoss ordering number |          | Typical Danfoss frequency converter series |               |               |
|--|-------------------------|-------------------------|----------|--|---------------|---------------|
|  |                         | AHF 005                 | AHF 010  | VLT 5000                                   | VLT 6000 HVAC | VLT 8000 AQUA |
| 19 A   | 10, 15                  | 175G6612                | 175G6634 | 5011, 5016                                 | 6011, 6016    | 8011, 8016    |
| 26 A   | 20                      | 175G6613                | 175G6635 | 5022                                       | 6022          | 8022          |
| 35 A   | 25, 30                  | 175G6614                | 175G6636 | 5027, 5032                                 | 6027, 6032    | 8027          |
| 43 A   | 40                      | 175G6615                | 175G6637 | 5042                                       | 6042          | 8032          |
| 72 A   | 50, 60                  | 175G6616                | 175G6638 | 5052, 5062                                 | 6052, 6062    | 8042, 8052    |
| 101 A  | 75                      | 175G6617                | 175G6639 | 5072                                       | 6072          | 8062, 8072    |
| 144 A  | 100, 125                | 175G6618                | 175G6640 | 5102, 5125                                 | 6102, 6122    | 8102, 8122    |
| 180 A  | 150                     | 175G6619                | 175G6641 | 5150                                       | 6150          | 8150          |
| 217 A  | 200                     | 175G6620                | 175G6642 | 5200                                       | 6175          | 8200          |
| 289 A  | 250                     | 175G6621                | 175G6643 | 5250                                       | 6225          | 8250          |
| Higher ratings can be achieved by paralleling the filter units |                         |                         |          |  |               |               |
| 324 A  | 300                     | 144 A and 180 A units   |          | 5300                                       | 6275          | 8300          |
| 397 A  | 350                     | 180 A and 217 A units   |          | 5350                                       | 6350          | 8350          |
| 506 A  | 450                     | 217 A and 289 A units   |          | 5450                                       | 6400          | 8450          |
| 578 A  | 500                     | Two 289 A units         |          | 5500                                       | 6500          | 8500          |

Description

\* Please note that the matching of the typical Danfoss frequency converter and filter is pre-calculated based on 480V and assuming typical motor load. VLT 5000 series is based on a 160 % torque application, while VLT 6000 and 8000 series are based on 110% torque application. The pre-calculated filter current may be varying from the input current ratings of VLT 5000, VLT 6000 and VLT 8000 series as stated in the respective operating instructions, as these numbers are based on different operating conditions.

■ Calculation of the exact filter size needed

For optimal performance the harmonic filter should be sized for the line input current to the frequency converter, i.e. the input current drawn based on the expected load of the frequency converter and not the size of the frequency converter itself!

The line input current to the frequency converter (I<sub>FC,L</sub>) can be calculated using the nominal motor current (I<sub>M,N</sub>) and displacement power factor (Cos φ) of the motor. Both data are normally printed on the nameplate of the motor. In the case where the nominal motor voltage (U<sub>M,N</sub>) is unequal to the actual line-line voltage (U<sub>L</sub>) the calculated current

must be corrected with the ratio between these voltages as shown in the equation below.

$$I_{FC,L} = 1.1 * I_{M,N} * Cos(\varphi) * ((U_{M,N}) / (U_L))$$

The harmonic filter chosen must have a nominal current (I<sub>AHF,N</sub>) equal to or larger than the calculated frequency converter line input current (I<sub>FC,L</sub>).

If several frequency converters are to be connected to the same filter, the harmonic filter must be sized according to the sum of the calculated line currents.



If the harmonic filter is sized for the load, and the motor of the corresponding frequency converter is changed, the current must be re-calculated to avoid overload of the harmonic filter.

**General technical data**

|  |                | AHF 0xx  | AHF 0xx  |
|--|----------------|--|--|
| Nominal supply voltage                 | $U_{L,N}$ [V]  | $380 \leq U_{L,N} \leq 415$  | $440 \leq U_{L,N} \leq 480$                                      |
| Tolerance of the actual supply voltage | $U_L$ [V]      | $342 \leq U_L \leq 456$  | $396 \leq U_L \leq 528$  |
| Supply frequency                       | $f_{i,N}$ [Hz] | $50 \pm 5 \%$  | $60 \pm 5 \%$  |
| Overload capability                    |                | 1,6 for 60s  |  |
| Efficiency                             | $\eta$ [%]     | ~ 98,5 %   |  |
| THiD                                   | [%]            | AHF 005 < 5%<br>AHF 010 < 10%  |  |
| $\cos \phi$ of $I_L$                   |                | 0.85 cap<br>0.99 cap<br>1.00   | at 75% $I_{AHF,N}$<br>at 100% $I_{AHF,N}$<br>at 150% $I_{AHF,N}$ |
| Power derating                         | [%/C]<br>[%/m] | $40^\circ\text{C} < T_a < 55^\circ\text{C} \Rightarrow 3\%/C$<br>1000m altitude above sea level. < $h \leq 4000\text{m}$ altitude above sea level $\Rightarrow 5\%/1000\text{m}$ |  |

**NB!:**

The reduction of the low harmonic current emission to the rated THiD implies, that the THvD of the non-influenced mains voltage is lower than 2% and the ratio of short circuit power to installed load ( $R_{SCE}$ ) is at least 66. Under these conditions the THiD of the mains current of the frequency converter is reduced to 10% or 5% (typical values at nominal load). If these conditions are not or only partially fulfilled, a significant reduction of the harmonic components can still be achieved, but the rated THiD values may not be achieved.

**Environmental data**

|                                |   |
|--------------------------------|---|
| Permissible temperature range* | During transport of the unit: $-25^\circ\text{C} \dots +70^\circ\text{C}$ (to VDE 0160)<br>During storage of the unit: $-25^\circ\text{C} \dots +55^\circ\text{C}$ (to VDE 0160)<br>During operation of the unit: $5^\circ\text{C} \dots +40^\circ\text{C}$ without power derating<br>$5^\circ\text{C} \dots +55^\circ\text{C}$ with power derating |
| Humidity class*                | Humidity class F without condensation ( 5% - 85% relative humidity)   |
| Installation height $h^*$      | $H \leq 1000$ m altitude above sea level without power derating<br>$1000$ m altitude above sea level < $h \leq 4000$ m altitude above sea level with power derating   |
| Degree of pollution            | VDE 0110 Part 2 degree 2  |
| Insulation strength            | Overvoltage category III according to VDE 0110  |
| Packaging                      | DIN 55468 for transport packaging materials   |
| Type of protection             | IP 20   |
| Approvals                      | CE: Low-Voltage Directive; UL; C-tick   |

\*climatic conditions according to class 3K3 (EN 50178 Part 6.1)

**■ Dimensions/weight**

The AHF-modules are available in six frame sizes (size B to G).  
For dimensions see the drawings on the following pages

| AHF 010, 380 – 415 V AC, 50Hz |            |                  | AHF 010, 440 – 480 V AC, 60Hz |            |                  |
|-------------------------------|------------|------------------|-------------------------------|------------|------------------|
| IAHF,N                        | Frame size | Weight           | IAHF,N                        | Frame size | Weight           |
| 10 A                          | B          | 19 Kg (42 lbs)   |                               |            |                  |
| 19 A                          | B          | 21 Kg (46 lbs)   | 19 A                          | B          | 23 Kg (51 lbs)   |
| 26 A                          | B          | 22 Kg (48 lbs)   | 26 A                          | B          | 34 Kg (75 lbs)   |
| 35 A                          | B          | 31 Kg (68 lbs)   | 35 A                          | B          | 40 Kg (88 lbs)   |
| 43 A                          | C          | 38 Kg (84 lbs)   | 43 A                          | C          | 45 Kg (99 lbs)   |
| 72 A                          | D          | 56 Kg (123 lbs)  | 72 A                          | D          | 61 Kg (134 lbs)  |
| 101 A                         | D          | 69 Kg (152 lbs)  | 101 A                         | D          | 75 Kg (165 lbs)  |
| 144 A                         | D          | 97 Kg (214 lbs)  | 144 A                         | D          | 95 Kg (209 lbs)  |
| 180 A                         | E          | 103 Kg (227 lbs) | 180 A                         | E          | 107 Kg (236 lbs) |
| 217 A                         | E          | 112 Kg (247 lbs) | 217 A                         | E          | 119 Kg (262 lbs) |
| 289 A                         | F          | 135 Kg (298 lbs) | 289 A                         | F          | 145 Kg (320 lbs) |
| 324 A                         | F          | 180 Kg (397 lbs) |                               |            |                  |

| AHF 005, 380 – 415 V AC, 50Hz |            |                  | AHF 005, 440 – 480 V AC, 60Hz |            |                  |
|-------------------------------|------------|------------------|-------------------------------|------------|------------------|
| IAHF,N                        | Frame size | Weight           | IAHF,N                        | Frame size | Weight           |
| 10 A                          | B          | 21Kg (46 lbs)    |                               |            |                  |
| 19 A                          | B          | 25 Kg (55 lbs)   | 19 A                          | B          | 29 Kg (64 lbs)   |
| 26 A                          | C          | 28 Kg (62 lbs)   | 26 A                          | C          | 40 Kg (88 lbs)   |
| 35 A                          | C          | 39 Kg (86 lbs)   | 35 A                          | C          | 50 Kg (110 lbs)  |
| 43 A                          | D          | 50 Kg (110 lbs)  | 43 A                          | D          | 52 Kg (115 lbs)  |
| 72 A                          | D          | 74 Kg (163 lbs)  | 72 A                          | D          | 89 Kg (196 lbs)  |
| 101 A                         | E          | 82 Kg (181 lbs)  | 101 A                         | E          | 150 Kg (331 lbs) |
| 144 A                         | E          | 130 Kg (287 lbs) | 144 A                         | E          | 169 Kg (373 lbs) |
| 180 A                         | F          | 144 Kg (317 lbs) | 180 A                         | F          | 178 Kg (392 lbs) |
| 217 A                         | F          | 162 Kg (357 lbs) | 217 A                         | F          | 225 Kg (496 lbs) |
| 289 A                         | G          | 201 Kg (443 lbs) | 289 A                         | G          | 273 Kg (602 lbs) |
| 324 A                         | G          | 255 Kg (562 lbs) |                               |            |                  |



■ Dimension diagrams  
Frame size B

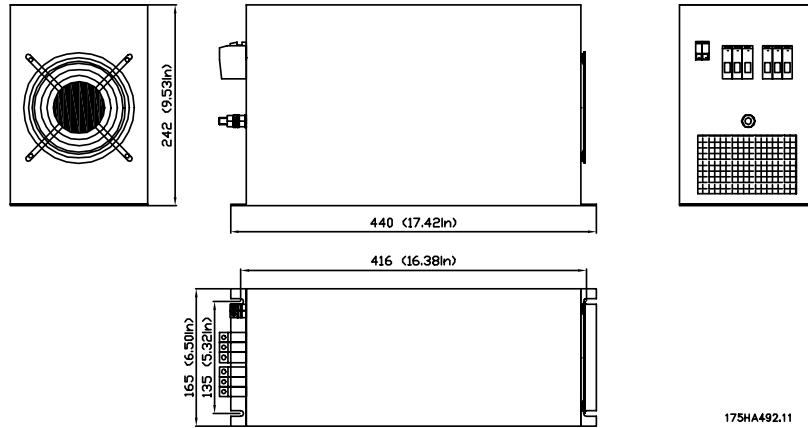

Frame size C

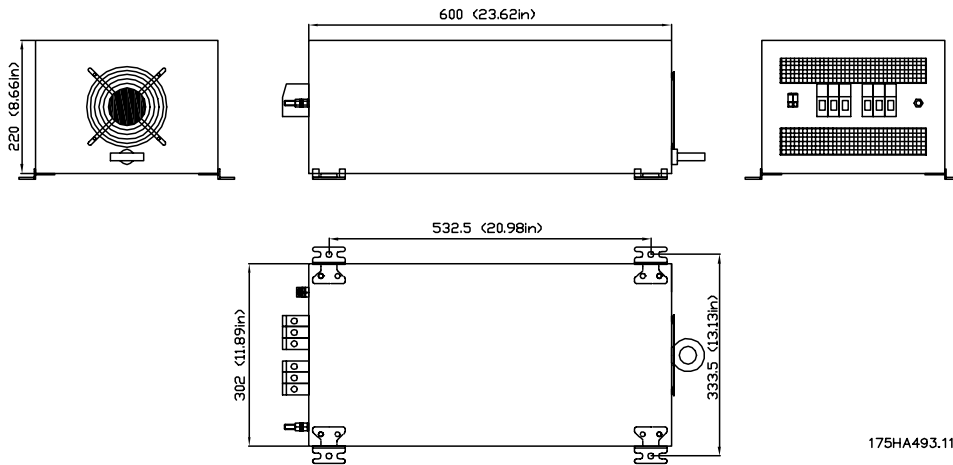

Frame size D

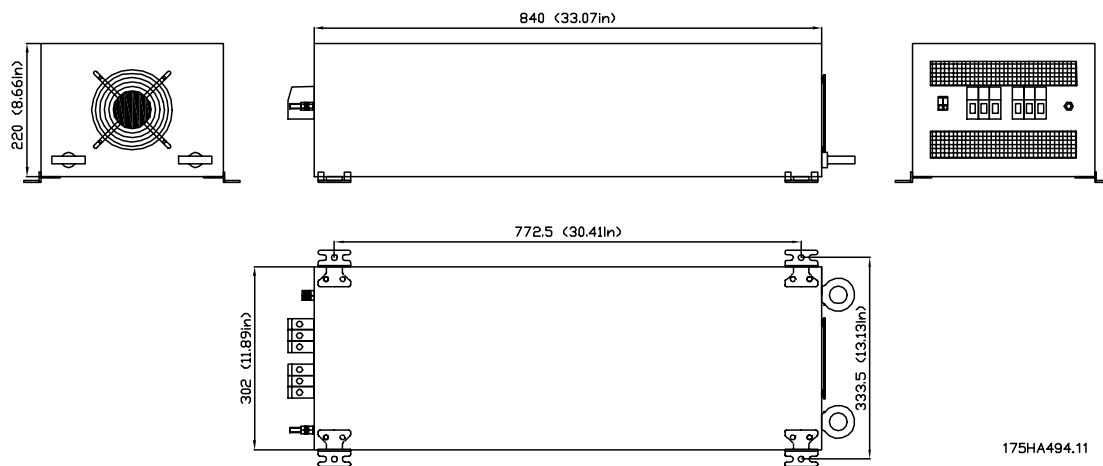

### Frame size E

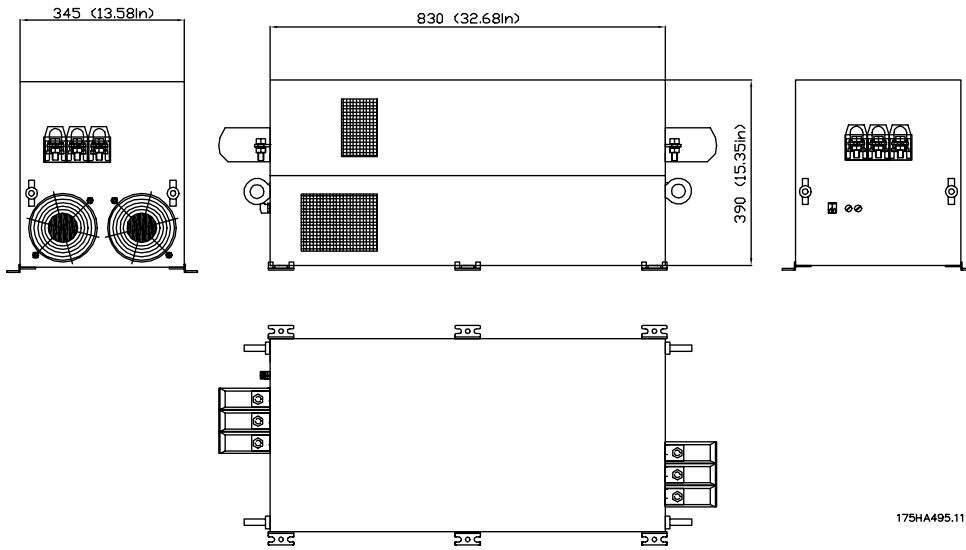

### Frame size F

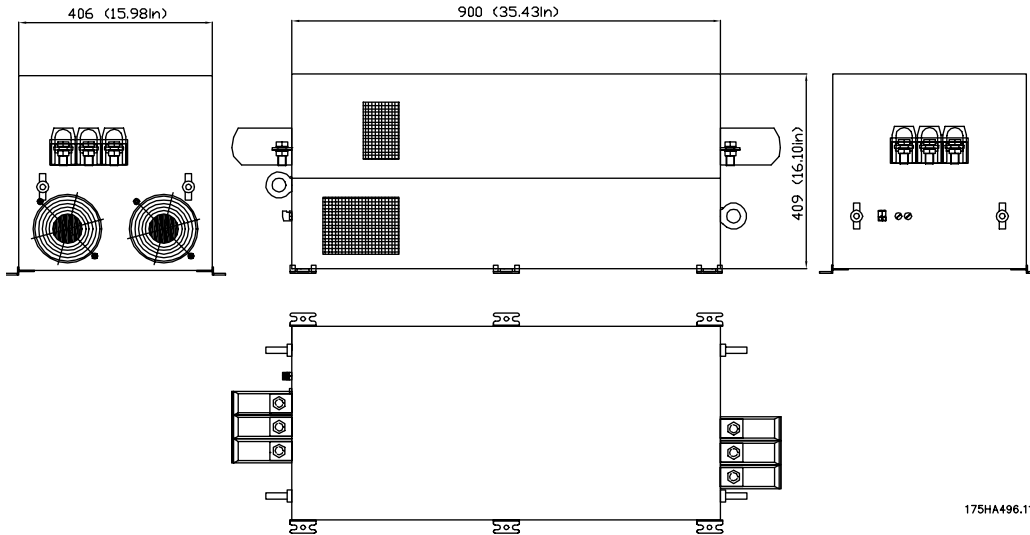

### Frame size G

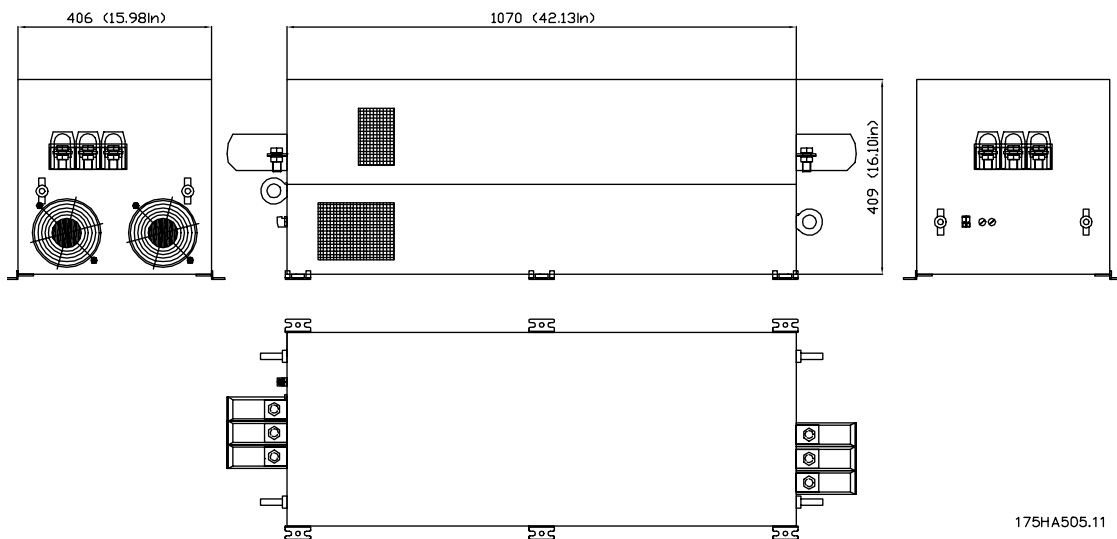

### ■ Mechanical installation

The encapsulation of the filters have an IP 20 rating. The modules can be mounted side by side with 60mm (2,36 inches) clearance.

To other components and to the cabinet walls keep a horizontal clearance of at least 70mm (2,76 inches) and a vertical clearance of at least 150mm (5,91 inches).



For versions with bus bars (frame size E – G) it is necessary to mount the added covers to the connectors in order to achieve the protection type IP 20.

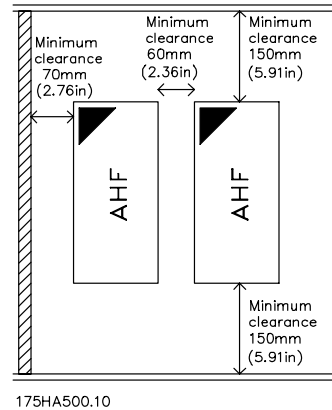

### ■ Ventilation

The filters are cooled by means of air circulation. Consequently, the air needs to be able to move freely above and below the filter module. The efficiency

of the filter modules is greater than 0.98. When installing a filter module in a panel or another enclosure, ensure there is sufficient airflow through the enclosure to limit heat rise in the enclosure.

| AHF 0xx<br>380 – 415V | Max.<br>Heat | AHF 0xx<br>440 – 480V | Max.<br>Heat |
|-----------------------|--------------|-----------------------|--------------|
| 10 A                  | 108 W        | 19 A                  | 236 W        |
| 19 A                  | 205 W        | 26 A                  | 324 W        |
| 26 A                  | 280 W        | 35 A                  | 436 W        |
| 35 A                  | 377 W        | 43 A                  | 536 W        |
| 43 A                  | 463 W        | 72 A                  | 898 W        |
| 72 A                  | 776 W        | 101 A                 | 1260 W       |
| 101 A                 | 1089 W       | 144 A                 | 1796 W       |
| 144 A                 | 1553 W       | 180 A                 | 2245 W       |
| 180 A                 | 1941 W       | 217 A                 | 2706 W       |
| 217 A                 | 2340 W       | 289 A                 | 3604 W       |
| 289 A                 | 3116 W       |                       |              |
| 324 A                 | 3493 W       |                       |              |



#### NB!:

If other heat sources (e.g. Danfoss frequency converters) are installed in an enclosure with the harmonic filter AHF 0xx, this heat generation must also be considered when calculating required airflow



#### NB!:

If the cooling air is polluted (dust, dirt swirl, grease, aggressive gas) the function of the filter module may be impeded. Ensure sufficient countermeasures, e.g. separate cooling air, mounting of air filters, periodical cleaning.

### ■ Power wiring

#### Standard connection

Supply voltage must be connected to the terminals X1.1, X1.2 and X1.3. The frequency converter supply terminals L1, L2 and L3 must be connected to the filter module terminals X2.1, X2.2 and X2.3.

#### Paralleling of FC's

If several frequency converters are to be connected to the harmonic filter, the connection is similar to the standard connection - The supply terminals L1, L2 and L3 of several frequency converters must be connected to the filter module terminals X2.1, X2.2 and X2.3.



**NB!:**

If several FC's are to be connected to the same filter, the harmonic filter must be sized according to the sum of the calculated input current to the FC's.

**Paralleling of filters**

If the line input current of the frequency converter exceeds the nominal current of the largest harmonic filter, several harmonic filters can be paralleled to achieve the necessary rating. Supply voltage must be connected to the terminals X1.1, X1.2 and X1.3 of the filters. The frequency converter supply terminals L1, L2 and L3 must be connected to the filter modules terminals X2.1, X2.2 and X2.3.



**NB!:**

Filters of different current ratings can be paralleled. The rating of the filter becomes the sum of the individual current ratings.



Use cables complying with local regulations.

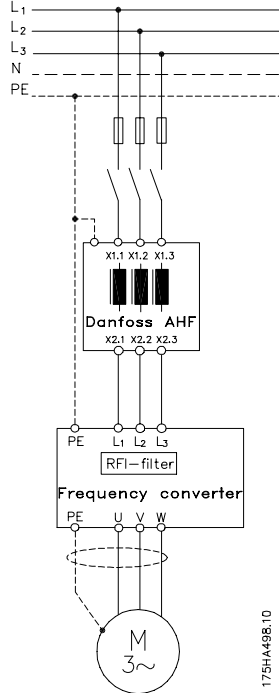

175HA496.10

■ **Over temperature contactor**

The Danfoss harmonic filter AHF 005 and AHF 010 is equipped with a galvanic isolated contactor that is closed under normal operating conditions and open if the filter is overheated. This contactor can be used for preventing damages to the filter caused by over temperature as shown in the following example.

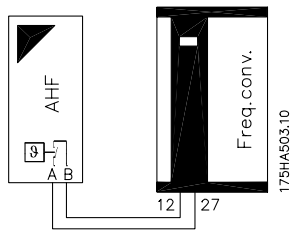

Example: Connect terminal A of the harmonic filter to terminal 12 or 13 (voltage supply digital input, 24V) of the Danfoss frequency converter and terminal B to terminal 27 (digital input "Coast Inverse") the frequency converter will let go of the motor (coasting) and thereby unload the filter if a over temperature is detected.



**NB!:**

The maximum rating of the over temperature contactor is 250V AC and 10A.

■ Power wiring size (copper)

| Enclosure          | Max. cable size mm <sup>2</sup> (AWG) | Type      |
|--------------------|---------------------------------------|-----------|
| A                  | 16 (6)                                | Connector |
| B                  | 16 (6)                                | Connector |
| C                  | 50 (1/0)                              | Connector |
| D                  | 50 (1/0)                              | Connector |
| E                  | *                                     | Bus Bars  |
| F                  | *                                     | Bus Bars  |
| G                  | *                                     | Bus Bars  |
| Overheat Contactor | 4 (10)                                | Connector |

\*Power wiring used for connection of the filter AHF 005 and AHF 010 in enclosure size E, F and G must be terminated with cable lugs that can be attached to the input and output bus bars terminals. This

type of termination imposes no specifications of the minimum and maximum cable size suitable for connection. Power terminal details regarding the bus bars can be found in the figures below.

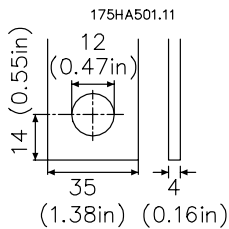

**Frame E**

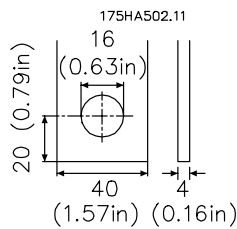

**Frame F**

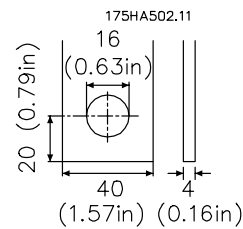

**Frame G**

■ Operation on different mains type

| Mains type |                                | Operation of the filter module |
|------------|--------------------------------|--------------------------------|
| TN         | Directly grounded star point   | Allowed                        |
| TN         | Indirectly grounded star point | Allowed                        |
| IT         | Isolated star point            | Allowed                        |

The filter module has been designed completely symmetrically for three phase operation and without reference to the star point or protective earth.

### ■ Typical installation in a panel or other enclosures

To avoid high frequency noise coupling keep a minimum distance of 150 mm (5.91 inches) to:

- a) mains/supply wires
- b) motor wires of frequency converter
- c) control- and signal wires (voltage range < 48 V)

To obtain low resistive HF-connections, grounding, screening and other metallic connections (e. g. mounting plates, mounted units) should have a surface as large as possible to metallic ground. Use grounding and potential equalisation wires

with a cross section as large as possible (min. 10mm<sup>2</sup>) or thick grounding tapes.

Use copper or tinned copper screened wires only, as steel screened wires are not suitable for high frequency applications. Connect the screen with metal clamps or metal glands to the equalisation bars or PE-connections.

Inductive switching units (relay, magnetic contactor etc.) must always be equipped with varistors, RC-circuits or suppressor diodes.

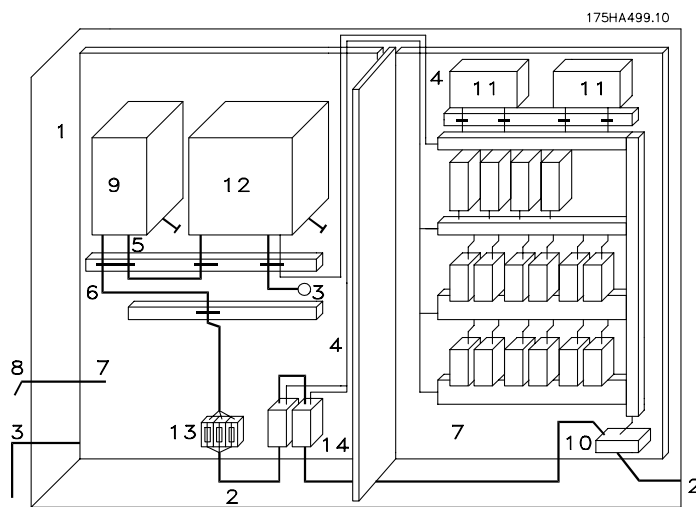

1. Panel
2. Mains supply wire
3. Motor wiring
4. Control wiring
5. Wiring between harmonic filter and frequency converter
6. Mains supply wire of filter module
7. Mounting plate (common star point)
8. Potential equalisation
9. Filter module AHF 0xx
10. Mains connection
11. PLC
12. Frequency converter
13. Mains fuses
14. Mains circuit breaker

■ **Commissioning**



Prior to initial switch-on of the filter module check the wiring for completeness, short-circuit and earth fault.



If the wiring is not correct, a non-intended operation of controller and/or filter module is possible.

**First powering up**

1. Switch on mains supply :
  - The filter module is ready for operation at once.
2. Check the readiness of the frequency converter:
  - Proceed in accordance with the operating instructions of the frequency converter.

**■ 1. General**

During operation, filter modules unit may have, according to their type of protection, live, bare, in some cases also movable or rotating parts as well as hot surfaces.

Non - authorized removal of required cover, inappropriate use, incorrect installation or operation, creates the risk of severe injury to persons or damage to material assets.

Further information can be obtained from the documentation.

All operations concerning transport, installation and commissioning as well as maintenance must be carried out by qualified, skilled personnel (IEC 364 and CENELEC HD 384 or DIN VDE 0100 and IEC-Report 664 or DIN VDE 0110 and national regulations for the preventions of accidents must be observed).

According to this basic safety information qualified skilled personnel are persons who are familiar with the erection, assembly, commissioning and operation of the product and who have the qualifications necessary for their occupation .

---

**■ 2. Application as directed**

Filter modules are components, which are designed for installation in electrical systems or machinery. When installing in machines, commissioning of the filter modules (i.e. the starting of operation as directed) is prohibited until it is proven, that the machine corresponds to the regulations of the EC Directive 83/392/EEC (Machinery Directive); EN 60204 must be observed.

Commissioning (i.e. starting operation as directed) is only allowed when there is compliance with the EMC-Directive 89/336/EEC.

The filter modules meet the requirements of the Low-Voltage Directive 73/23/EEC. The technical data and information on the connection conditions must be obtained from the nameplate and the documentation and must be observed in all cases.

---

**■ 3. Transport, Storage**

Notes on transport, storage and appropriate handling must be observed.

The filter modules have to be protected from inadmissible stress. In particular during transport and handling no components are allowed to be bend

and / or isolating distances may not be altered. The units are equipped with electrostatic sensitive devices, which may be damaged by improper handling. Therefore it has to be avoided to get in contact with electronic components. If electronic components are damaged mechanically the unit must not be put into operation, as it cannot be ensured, that all relevant standards are observed. Climatic conditions must be observed according to prEN 50178.

---

**■ 4. Installation**

The devices must be erected and cooled according to the regulations of the corresponding documentation.

The filter modules must be protected from inappropriate loads. Particularly during transport and handling, components must not be bent and / or isolating distances must not be changed. Touching of electronic components and contacts must be avoided.

Filter modules contain electro-statically sensitive components, which can easily be damaged by inappropriate handling. Electrical components must not be damaged or destroyed mechanically (health risk are possible!).

---

**■ 5. Electrical Installation**

When working on live filter modules, the valid national regulations for the prevention of accidents (e.g. VBG 4) must be observed. Before any installation or connection works, the plant has to be switched off and to be secured properly.

The electrical installation must be carried out according to the appropriate regulations (e.g. cable cross-sections, fuses, PE-connection). More detailed information is included in the documentation. When using the filter module with frequency converters without safe separation from the supply line (to VDE 0100) all control wiring has to be included in further protective measures (e.g. double insulated or shielded, grounded and insulated).

---

**■ 6. Operation**

Systems where filter modules are installed, if applicable, have to be equipped with additional monitoring and protective devices according to the valid safety regulations e.g. law on technical tools, regulations for the prevention of accidents, etc.



After disconnecting the filter module from the supply voltage, live parts of the filter module and power connections must not be touched immediately, because of possibly charged capacitors.

During operation, all covers and doors must be closed.

---

#### ■ 7. Maintenance and service

The manufacturer's documentation must be observed.

#### **This safety information must be kept!**

The product-specific safety and application notes in these Operating Instructions must also be observed!

---

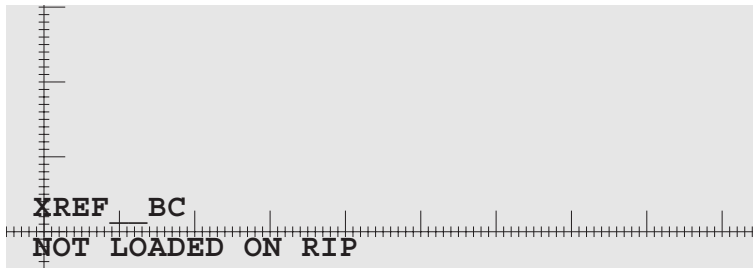

## Harmonic Filter AHF 005/010



## Instruction Manual

**VLT**<sup>®</sup> frequency converters **BAUER** geared motors

Danfoss can accept no responsibility for possible errors in catalogues, brochures and other printed material. Danfoss reserves the right to alter its products without notice. This also applies to products already on order provided that such alterations can be made without subsequential changes being necessary in specifications already agreed. All trademarks in this material are property of the respective companies. Danfoss and the Danfoss logotype are trademarks of Danfoss A/S. All rights reserved.

