

■ Contents

Introduction	3
About this manual	3
Assumptions	3
What you should already know	3
Available literature	4
Supplied with the unit	4
Product and Environment	5
Network	5
User Profile	5
Interface to DeviceNet Network	5
Data Communication Interface	5
Overall Function	5
Control Card Self-test	5
 Technical Data	 6
Cable Lengths	6
Topology	6
Cable Specifications	6
Network Power Supply	6
Cable Cross Section	6
EMC Precautions	7
VLT Response Time	8
 Electrical Installation	 9
VLT 2800 Connection of the Cable Screen	9
VLT 2800 Earth Connection	10
VLT 2800 DeviceNet Connection	10
FCD 300 Electrical connection	11
User Interface	12
Quick Setup	13
 Master-Slave configuration	 14
 Drive Profile	 15
I/O Assembly Instances	15
Control Word and Status Word under Instance 20/70	16
Control Word and Status Word under Instance 21/71	17
Bus speed reference value, under Instance 20/70 and 21/71	19
Actual output speed, under Instance 20/70 and 21/71	19
Control Word and Status Word under Instance 100/150 and 101/151	20
Bus reference value	23
Actual output frequency	23
Process Data, PCD	24
 DeviceNet object classes	 25
Class Code 0x01	25

Class Code 0x02	25
Class Code 0x03	25
Class Code 0x04	26
Class Code 0x05	26
Class Code 0x28	30
Class Code 0x29	31
Class Code 0x2A	32
Danfoss Classes	33
DeviceNet Operation Mode	34
Bit Strobe	34
Polling	35
Change of State, COS	35
EDS Files	36
VLT 2800 US version with DeviceNet	36
VLT 2800 European version with DeviceNet	36
FCD 300 European version with DeviceNet	37
Programming	38
Special Attention	38
Warning and Alarm Messages	45
Abbreviations	46
Factory settings - VLT 2800	47
Factory settings - FCD 300	55
Additional control features for VLT 2800	62

■ Introduction

■ About this manual

This manual is intended to be used both as an instructional and as a reference manual. It only briefly touches on the basics of the DeviceNet protocol. Whenever it is necessary for gaining an understanding of the AC Drive Profile, please refer to the ODVA version 2.0.

The manual is also intended to serve as a guideline when you specify and optimize your communication system.

Even if you are an experienced DeviceNet programmer, we suggest that you read this manual in its entirety before you start programming, since important information can be found in all chapters.

■ Assumptions

This manual assumes that you are using a DANFOSS VLT 2800 or FCD 300 unit with DeviceNet. It is also assumed that you are using a PLC or PC, as a master, that is equipped with a serial communication card supporting all the DeviceNet communication services required by your application. Further more it is assumed that all requirements stipulated in the DeviceNet standard as well as those set up in the AC Drive Profile and those pertaining to the VLT Variable Speed Drive are strictly observed as well as all limitations therein fully respected.

■ What you should already know

The DANFOSS DeviceNet is designed to communicate with any master abiding by the DeviceNet standard. It is therefore assumed that you have full knowledge of the PC or PLC you intend to use as a master in your system. Any questions pertaining to hardware or software produced by any other manufacturer is beyond the scope of this manual and is of no concern to DANFOSS.

If you have questions about how to set up master - master communication or communication to a non-Danfoss slave, the appropriate manuals should be consulted.

■ Available literature**■ Supplied with the unit**

Below is a list of the literature available for VLT 2800 and FCD 300. It must be noted that there may be deviations from one country to the next.

Supplied with the unit:

Operating instructions	MG.28.AX.YY
Quick setup	MG.28.AX.62
Parameter list	MG.28.DX.YY

Various literature:

Design Guide for VLT 2800	MG.28.EX.YY
Data sheet for VLT 2800	MD.28.AX.YY
Design Guide for FCD 300	MG.04.AX.YY
Data sheet for FCD 300	MD.04.AX.YY

Instructions for VLT 2800:

Assembly/disassembly	MI.28.A1.02
LCP remote-mounting kit	MI.56.AX.51
Filter instruction	MI.28.B1.02

Communication with VLT 2800 and FCD 300:

Profibus manual	MG.90.AX.YY
VLT 2800 DeviceNet manual	MG.90.BX.YY

X = version number

YY = language version

■ Product and Environment

DeviceNet is a distributed control network. The DeviceNet protocol is embedded in the control card and is a communication protocol conforming to the Open DeviceNet Vendor Association (ODVA) standard.

The control card allows DeviceNet compatible controllers, sensors, and network management tools to control, monitor, and supervise the VLT frequency converter. The control card is designed to the DeviceNet System Protocol for Vendors as a slave device.

■ Network

The VLT frequency converter will function as a slave on the DeviceNet network. All addressing and linking to nodes is done at installation time by a network manager tool. The network installer and the network management master have a significant influence on how the node functions on the network. A DeviceNet network can support up to 64 nodes.

■ User Profile

The end-user is a network manager programmer or a controller who see the DeviceNet control card as a transparent bridge to the VLT frequency converter. Control and supervision of the VLT frequency converter will still be possible through the standard parameter set.

■ Interface to DeviceNet Network

The Interface connection to the DeviceNet network is implemented through a CAN chip. Four different I/O Assembly is available in the VLT frequency converter DeviceNet interface, which can be configured by the user. The I/O assembly can handle Polled mode, Bit Strobe, Change of state (COS) and Cyclic. For explicit messages, the interface has two Unconnected Messages Manager (UCMM) available. This allows two nodes on the DeviceNet to directly access parameters in the VLT frequency converter without involving a pre-configured master.

■ Data Communication Interface

No direct data communication interface (e.g. via a serial port) other than the DeviceNet interface and the VLT frequency converter interface is considered.

LCP2 or Dialog can be used on the Sub D plug while using DeviceNet.

■ Overall Function

DeviceNet is a low-level network that standardizes communications between industrial devices (sensors, limit switches) and high level devices (controllers). The communication network can be peer to peer or master/slave. DeviceNet uses CAN technology for Media Access Control and Physical Signaling and it supports up to 64 nodes. DeviceNet also defines device profiles for devices belonging to specific classes. For other devices, a custom class must be defined in order to make it DeviceNet compatible. This further enhances the interchangeability and interoperability of the network. Each node on the network has its own unique media access control identifier (MAC ID) to distinguish it on the network.

■ Control Card Self-test

Please refer to parameter 620 in the *Programming* chapter.

■ **Technical Data**

■ **Cable Lengths**

Baud Rate	Max. total cable length [m]	Drop Length	
		Maximum	Cumulative
125k baud	500 meters (1640 ft.)	6 meters (20 ft.) for one drop	156 meters (512 ft.)
250k baud	250 meters (820 ft.)		78 meters (256 ft.)
500k baud	100 meters (328 ft.)		39 meters (128 ft.)

■ **Topology**

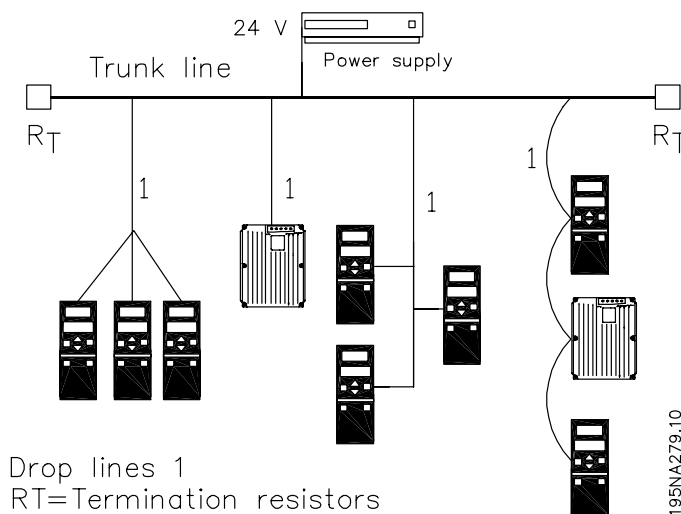

■ **Cable Specifications**

The cable is to be used according to ODVA specifications.

■ **Network Power Supply**

The DeviceNet option is an optically isolated node, where transceiver power is provided by the network. External network power supply requirements are:
11 - 25 VDC
10 mA draw per VLT frequency converter node.

■ **Cable Cross Section**

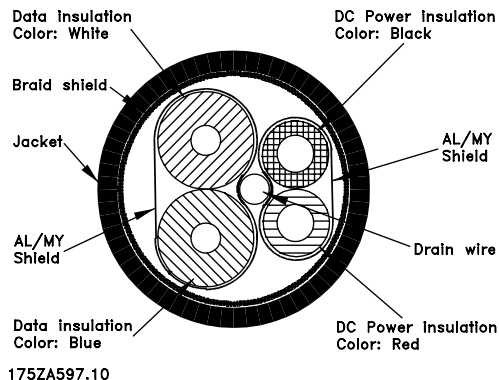

■ EMC Precautions

The following EMC precautions are recommended to obtain interference free operation of the DeviceNet network. Additional information on EMC can be found in the FCD 300 and in the VLT 2800 Series Operating Instructions and Design Guide.



NB!

Relevant national and local regulations, for example regarding protective earth connection, must be observed

to avoid coupling of high frequency noise from one cable to the other. Normally a distance of 200 mm (8 inches) is sufficient, but it is generally recommended to keep the greatest possible distance between the cables, especially where cables are running in parallel over long distances.

If the DeviceNet cable has to cross a motor and brake resistor cable they must cross each other at an angle of 90°.

The DeviceNet communication cable must be kept away from motor and brake resistor cables

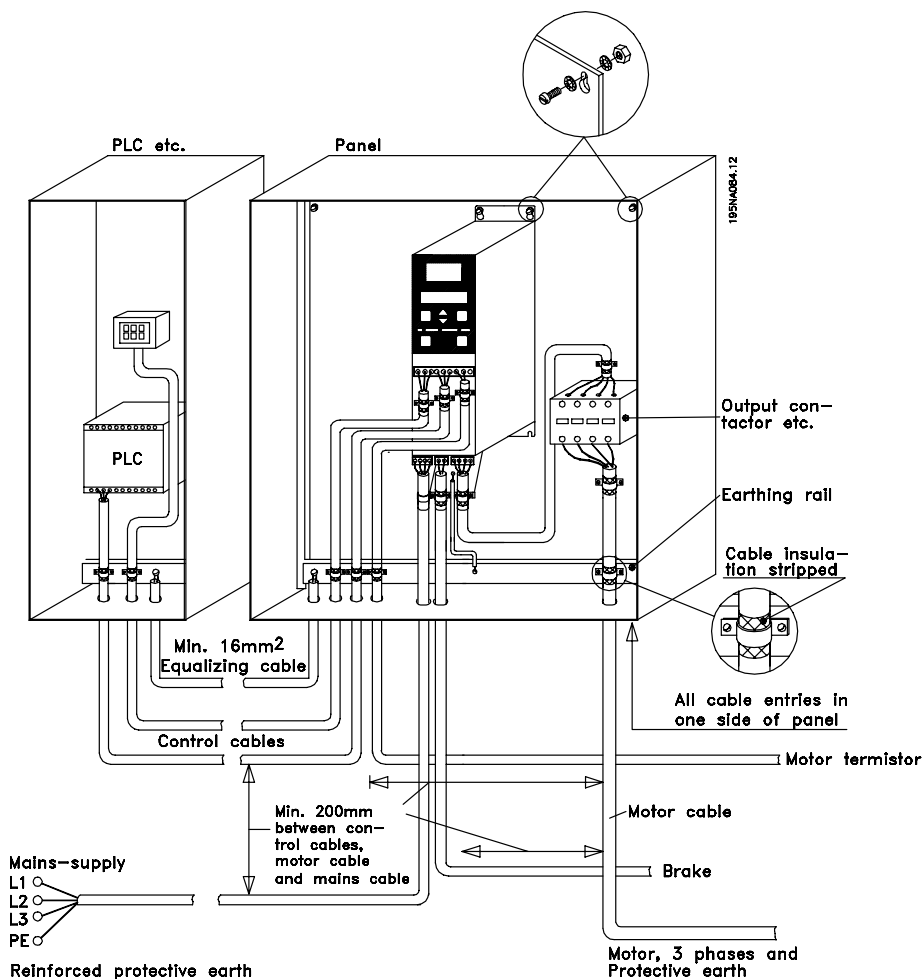

Example: VLT 2800 panel mounting

Technical Data

■ VLT Response Time

The update time via the DeviceNet connection can be divided into two parts:

1. The communication time, which is the time it takes to transmit data from the master to the slave (VLT with DeviceNet option).
2. The internal update time, which is the time it takes to transmit data between the VLT frequency converter control card and the DeviceNet interface.

Communication time (t_{com}) depends on the actual transmission speed (baudrate) and the type of master in use. More slaves or lower transmission speed will increase the communication time.

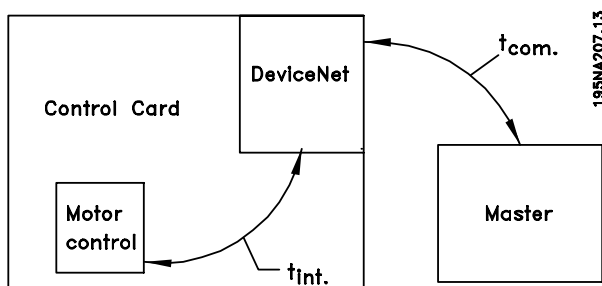

Data	Update time, t_{int}
Control word via I/O instances	14 msec
Main actual value via I/O instances	44 msec
Status word via I/O instances	14 msec
Reference via I/O instances	44 msec
Control via Class Code 0x29	14 msec
Reference via Class Code 0x2A	44 msec
Change of parameter via Explicit message and Danfoss Object	94 msec
Read of parameter via Explicit message and Danfoss Object	14 msec

■ Electrical Installation

■ VLT 2800 Connection of the Cable Screen

Danfoss recommends that the screen of the DeviceNet cable be connected to ground at both ends of the cable at every DeviceNet station (see *Danfoss recommendation* for further details).

It is very important to have a low impedance ground connection of the screen, also at high frequencies. This can be obtained by connecting the surface of the screen to ground, for example by means of a cable clamp or a conductive cable gland. VLT frequency converter Series are provided with different clamps and brackets to enable a proper ground connection of the DeviceNet cable screen. The screen connection is shown in the drawing.

For fulfilling the CE and EMC compliance.

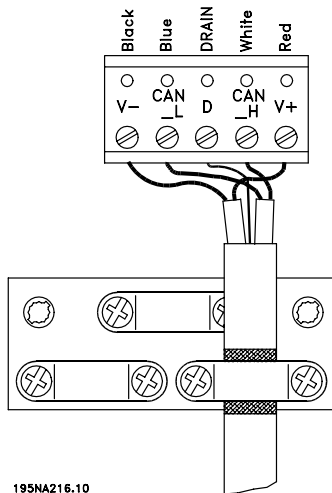

VLT 2800 ODVA recommendation

Screen must be connected to ground at only one point on the network.



NB!:

Please note, that this recommendation conflicts with the EMC correct installation.

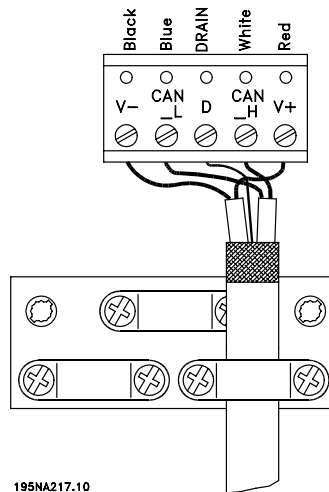

■ VLT 2800 Earth Connection

It is important that all stations connected to the DeviceNet network are connected to the same earth potential. The earth connection must have a low HF (high frequency) impedance. This can be achieved by connecting a large surface area of the cabinet to ground, for example by mounting the VLT frequency converter on a conductive rear plate. Especially when having long distances between the stations in a DeviceNet network it can be necessary to use additional potential equalizing cables, connecting the individual stations to the same earth potential.

■ VLT 2800 DeviceNet Connection

It is essential that the bus line be terminated properly. A mismatch of impedance may result in reflections on the line that will corrupt data transmission.

The DeviceNet control card is provided with a pluggable connector.

By using a pluggable connector as a splice between two trunk lines, removal of devices will not sever the network. Strain relief, if required, must be provided by the developer. In current installations of this type of connector, the strain relief is attached to the product.

NB!: Wires should not be installed while the network is active. This will prevent problems such as shorting the network supply or disrupting communications.

VLT 2800 Drop cable

An alternative to splicing two trunk lines in the connector on the control card, is using a DeviceNet connection box or a T-connector. For this kind of installation a drop cable is available as an option.

Drop cable ordering number: 195N3113

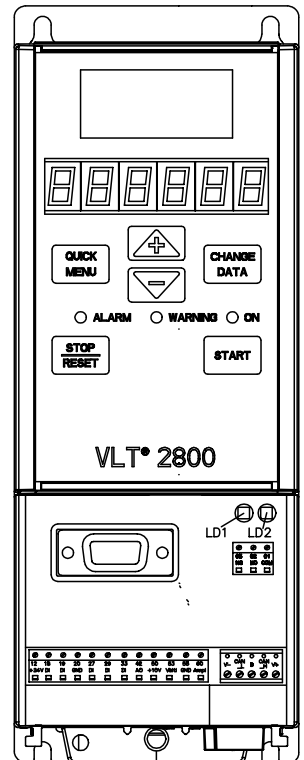
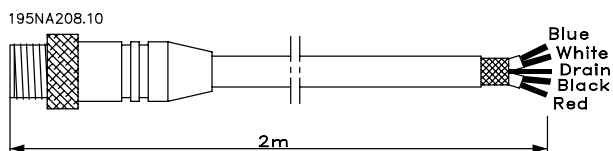

NB!: Please note, that terminal 46 has been removed from the DeviceNet card, meaning that parameter 341-342 are not having any function.

■ FCD 300 Electrical connection

The DeviceNet bus connection can be performed through a plug, that is to be mounted in the FCD 300 housing (M16 gland hole) and wired to the inside terminal strip.

Wiring list

M12 Circular connector	Terminal strip	Colour	Function
4	68	White	Can high
5	69	Blue	Can low
2	67	Red	+ 24 V
3	70	Black	GND
1	D	Green	Drain

DeviceNet plug 175N2279

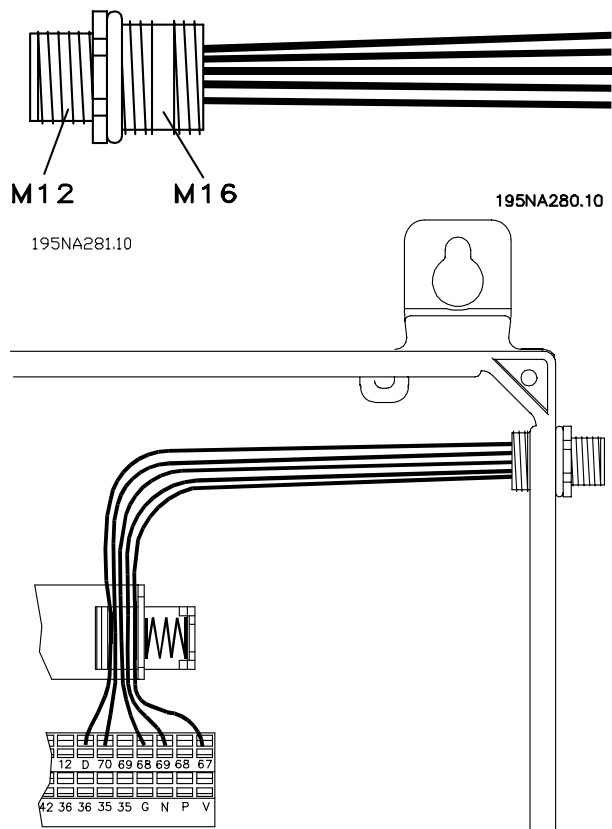

■ User Interface

The DeviceNet control card contains two bi-color (green/red) LED's for each connector hookup port, to indicate the state of the device and network, respectively.

Module LED:

LD1 on VLT 2800 Dual colour (Green/Red)	Yellow FCD 300 STATUS LED when selected as DeviceNet in parameter 26	VLT status
OFF	OFF	Device is OFF
GREEN	YELLOW	Device is operational
Flashing GREEN	Flashing YELLOW	Device is in standby
Flashing RED	OFF	Device detects a recoverable fault
RED	OFF	Device detects an unrecoverable fault
Flashing GREEN/RED	Flashing YELLOW	Device is self testing

NETWORK LED:

VLT status	LD2 on VLT 2800 Dual colour (Green/Red)	Green BUS LED on FCD 300	VLT status
Network is non-powered/not on-line	OFF	OFF	Network is non-powered/not on-line
Network is on-line but not connected	Flashing GREEN	Flashing GREEN	Network is on-line but not connected
Network is on-line and connected	GREEN	GREEN	Network is on-line and connected
Network has a connection timeout	Flashing RED	OFF	Network has a connection timeout
Network has a critical link failure	RED	OFF	Network has a critical link failure

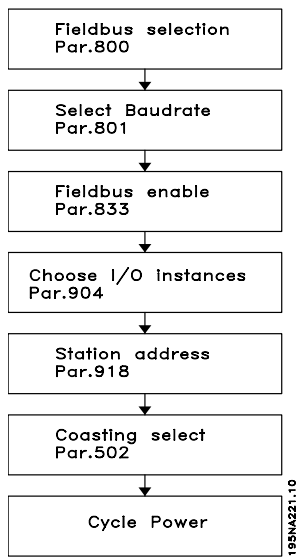
■ Quick Setup

- Parameter 800 = "Fieldbus selection".
Parameter 833 = "Fieldbus enable".
Parameter 918 = "Select Bus address".
Parameter 801 = "Select Baudrate".
Parameter 904 = "Choose I/O instances".
Parameter 502 = "Coasting select".
-

■ Master-Slave configuration

■ System configuration

The system configuration of a DeviceNet master and a VLT 2800/FCD 300 can be split up into two parts.

The first part is the setting of DeviceNet communication related parameters. These are the baud rate and station address/MAC ID.

By VLT 2800/FCD 300 these parameters can be set by the LCP or access via a DeviceNet configuration tool. None of these parameters can be set by mechanical switches.

After the baud rate and station address/MAC ID are set a connection to a DeviceNet DeviceNet configuration tool can be established.

The second and larger area of a system configuration is the setting of application related parameters.

EDS files are easy to create and it is strongly recommended to generate an EDS for each VLT 2800/FCD 300. This can be done by uploading the EDS file from each drive by a DeviceNet configuration tool. In the VLT 2800/FCD 300 EDS file it is possible to configure the drive and read or write to parameters.

The language of the EDS file is depending of the actual setting of parameter 001 *Language*.

In parameter 838 *EDS Data type* it is possible to choose between two dataformat for uploading EDS files. Before uploading the EDS file please check if the master support Errata 1 or Errata 2.

For Off-line configuration Danfoss can provide you with english EDS files, see section *EDS files* for the EDS file name. Contact your local Danfoss supplier for the EDS files.

Another important configuration parameter is the selection of communication mechanisms that enable an efficient and responsive I/O system. By VLT 2800/FCD 300 it is possible to choose between the following communication mechanisms:

- Poll I/O
- Bit Strobe I/O
- Change-of-state (COS) / Cyclic I/O
- Explicit Messaging

See *DeviceNet Operation Mode* in this manual for further information.

The last configuration parameter is the choice of Instance type in parameter 904 *PPO selection*. Here is it possible to select between a Danfoss Specific profile (Instance 100/150 or 101/151) or a ODVA Specific AC Drive profile (Instance 20/70 or 21/71).

■ Drive Profile

■ I/O Assembly Instances

The I/O Assembly Instance definitions in this section define the format of the "data" attribute (attribute 3) for I/O Assembly Instances. I/O Assemblies support a hierarchy of motor control devices. The device hierarchy includes motor starters, soft starters, AC and DC drives, and servo drives. Assembly Instances are numbered within the hierarchy so that each device type is assigned a range of Assembly Instance numbers, with higher functionality devices supporting

higher instance numbers. Devices in the hierarchy can choose to support instance numbers that are lower than theirs in the hierarchy. For example an AC drive may choose to support some I/O Assemblies in the starter profile to make it easier to interchange starters and drives within the system.

I/O Instances Par.904	Output assembly word	Input assembly word	Drive profile										
20/70	CTW <table border="1"><tr><td>Speed ref. RPM</td></tr></table>	Speed ref. RPM	STW <table border="1"><tr><td>Actual RPM</td></tr></table>	Actual RPM	ODVA								
Speed ref. RPM													
Actual RPM													
21/71	CTW <table border="1"><tr><td>Speed ref. RPM</td></tr></table>	Speed ref. RPM	STW <table border="1"><tr><td>Actual RPM</td></tr></table>	Actual RPM	ODVA								
Speed ref. RPM													
Actual RPM													
100/150	CTW <table border="1"><tr><td>MRV</td></tr></table>	MRV	STW <table border="1"><tr><td>MAV</td></tr></table>	MAV	DANFOSS								
MRV													
MAV													
101/151	<table border="1"><tr><td>CTW</td><td>MRV</td><td>User definable</td><td>PCD1</td><td>PCD2</td></tr></table>	CTW	MRV	User definable	PCD1	PCD2	<table border="1"><tr><td>STW</td><td>MAV</td><td>User definable</td><td>PCD1</td><td>PCD2</td></tr></table>	STW	MAV	User definable	PCD1	PCD2	DANFOSS
CTW	MRV	User definable	PCD1	PCD2									
STW	MAV	User definable	PCD1	PCD2									

195NA211.10

■ Control Word and Status Word under

Instance 20/70

Set parameter 904 *PPO type* to select Instance 20/70 [12].

The control word in Instance 20 is defined as following:

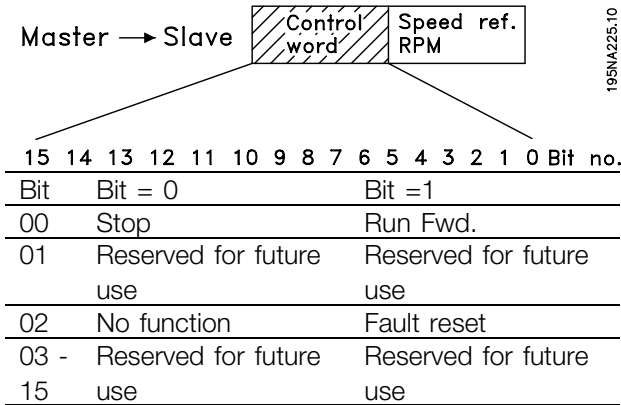

Bit 0, Run Fwd:

Bit 0 = "0" means that the VLT frequency converter has a stop command.

Bit 0 = "1" leads to a start command and the VLT frequency converter will start to run the motor.

Bit 2, Fault Reset

Bit 0 = "0" means that there is no reset of a trip.

Bit 0 = "1" means that a trip is reset.

Regarding the Speed reference, see section *Bus speed reference value, under Instance 20/70*

and 21/71.

The status word in Instance 70 is defined as following:

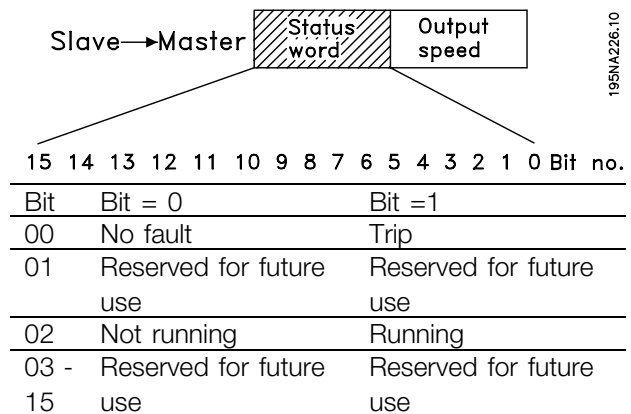

Bit 0, Fault:

Bit 0 = "0" means that there is no fault on the VLT frequency converter.

Bit 0 = "1" means that there is a fault on the VLT frequency converter.

Bit 2, Running

Bit 0 = "0" means that there is no active start command.

Bit 0 = "1" means that there is an active start command.

Regarding the Actual output speed, see section *Actual output speed, under Instance 20/70 and 21/71.*

■ Control Word and Status Word under Instance 21/71

Set parameter 904 *PPO type 1* to select Instance 21/71 [13].

The control word in Instance 21 is defined as following:

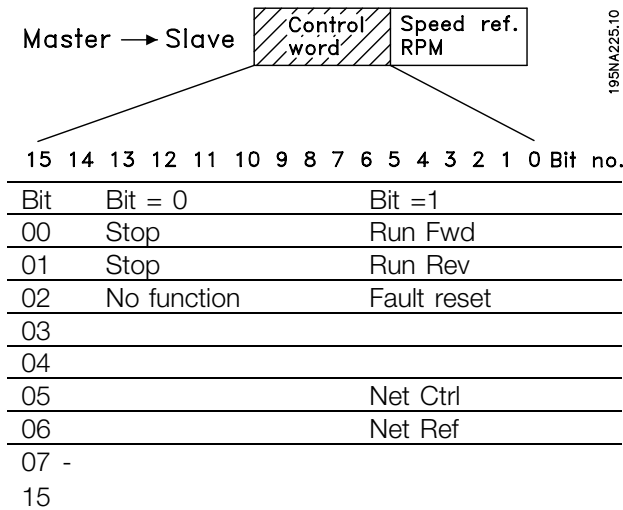

Bit 0, Run Fwd:

Bit 0 = "0" means that the VLT frequency converter has a stop command.

Bit 0 = "1" leads to a start command and the VLT frequency converter will start to run the motor clockwise.

Bit 1, Run Rev:

Bit 0 = "0" leads to a stop of the motor.

Bit 0 = "1" leads to a start of the motor.

Bit 2, Fault Reset:

Bit 0 = "0" means that there is no reset of a trip.

Bit 0 = "1" means that a trip is reset.

Bit 5, Net Ref:

NB!:



Please note, that a change will have an effect on parameter 502 - 506.

Bit 6, Net Ctrl:

NB!:



Please note, that a change will have an effect on parameter 214, 305, 307, 308 and 314.

Regarding the Speed reference, see section *Bus speed reference value, under Instance 20/70 and 21/71.*

The status word in Instance 71 is defined as following:

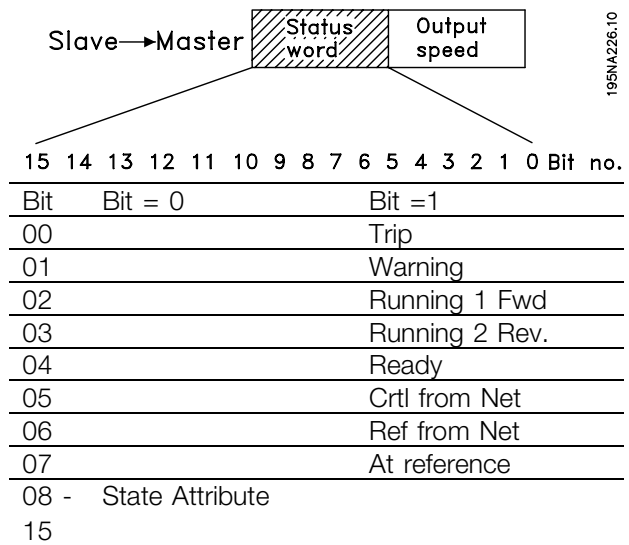

Bit 0, Fault:

Bit 0 = "0" means that there is no fault on the VLT frequency converter.

Bit 0 = "1" means that there is a fault on the VLT frequency converter.

Bit 1, Warning:

Bit 0 = "0" means that there is no unusual situation.

Bit 0 = "1" means that an abnormal condition has arisen .

Bit 2, Running 1:

Bit 2 = "0" means that the drive is not in one of these states or that Run 1 is not set.

Bit 2 = "1" means that the drive state attribute is enabled or stopping , or that Fault-Stop and bit 0 (Run 1) of the CTW is set at the same time.

Bit 3, Running 2:

Bit 3 = "0" means means, that the drive is not in one of these states or that Run 2 is not set.

Bit 3 = "1" means that the drive state attribute is enabled or stopping , or that fault-stop and bit 0 (Run 2) of the CTW is set at the same time.

Bit 4, Ready:

Bit 4 = "0" means that the state attribute is in another state.

Bit 4 = "1" means that the state attribute is ready or enabled or stopping.

Bit 5, Control from net:

Bit 5 = "0" means that the drive is controlled from the standard inputs.

Bit 5 = "1" means that DeviceNet has the control (start, stop, reverse) of the drive.

Bit 6, Ref from Net:

Bit 6 = "0" means that the reference comes from the drive's inputs.

Bit 6 = "1" means that the reference is coming from DeviceNet.

Bit 7, At reference:

Bit 7 = "0" means that the motor is running, but that the present speed is different from the preset speed reference, i.e. while the speed is being ramped up/down during start/stop.

Bit 7 = "1" means that the drive's speed equals the reference.

Bit 8 - 15, State attribute:

Represents the state attribute of the drive, as indicated in the following table:

Number	Meaning
0	(Vendor specific)
1	Startup
2	Not ready
3	Ready
4	Enabled
5	Stopping
6	Fault stop
7	Faulted

Regarding the Actual output speed, see section *Actual output speed*, under *Instance 20/70 and 21/71*

■ Bus speed reference value, under Instance 20/70 and 21/71

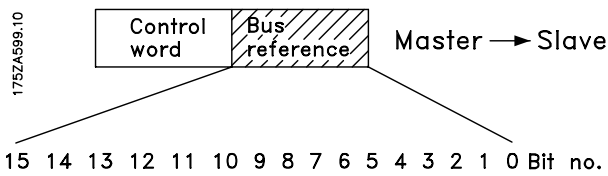

The speed reference value is transmitted to the VLT frequency converter in the form of a 16-bit word. The value is transmitted as a whole number. (Negative figures are formatted by means of 2's complement.)

The bus speed reference has the following format:

Parameter 203 = "0" ["ref_{MIN} ⇒ ref_{MAX}"]

0 (0000 Hex) [RPM] ⇒ + 32767 (7FFF Hex) [RPM]

Parameter 203 = "1" [- ref_{MAX} ⇒ + ref_{MAX}]

-32767 (8000 Hex) ⇒ +32767 [RPM] (7FFF Hex)

The actual reference [Ref. %] in the VLT depends on the settings, in the following parameters:

- 104 Motor frequency
- 106 Motor Nom. speed
- 205 Max. Reference

Note that, If the bus speed reference is negative, and the control word contains a run reverse signal, the drive runs clockwise.

■ Actual output speed, under Instance 20/70 and 21/71

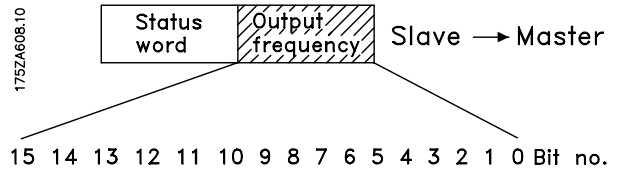

The value of the actual speed of the motor, is transmitted in the form of a 16-bit word.

The value is transmitted as a whole number. (Negative figures are formed by means of 2's complement.)

The actual speed value has the following format:

-32767 (8000 Hex) [RPM] ⇒ +32767 [RPM] (7FFF Hex) [RPM]

Control Word and Status Word under Instance
100/150 and 101/151

Set parameter 904 *PPO type 1* [10] to select Instance 100/150.

The control word in Instance 100/101 is defined as following:

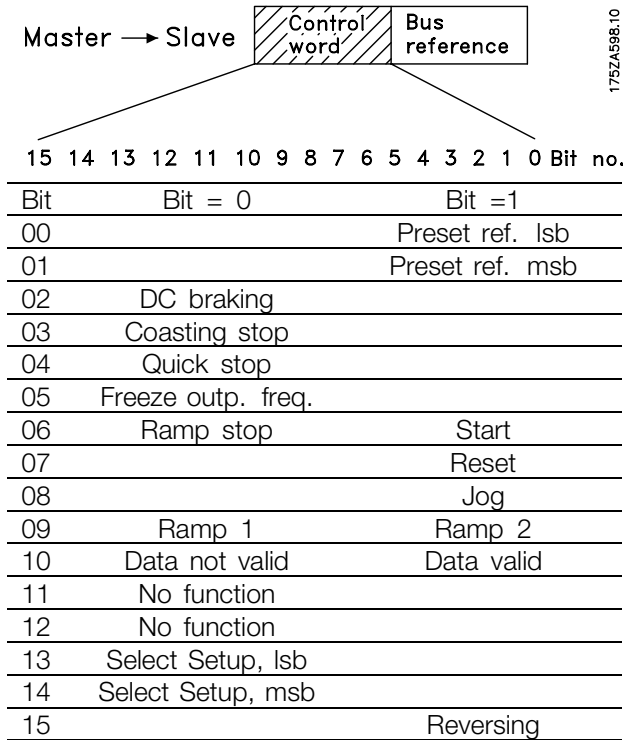
Bit 00/01:

Bit 00/01 is used to select between the two pre-programmed references (parameters 215-218 *Preset reference*) according to the following table:

Preset ref.	Parameter	Bit 01	Bit 00
1	215	0	0
2	216	0	1
3	217	1	0
4	218	1	1

NB!:

In parameter 508 *Selection of preset reference* a selection is made to define how Bit 00/01 gates with the corresponding function on the digital inputs.

Bit 02, DC brake:

Bit 02 = '0' causes DC braking and stop. Brake voltage and duration are preset in parameters 132 *DC brake voltage* and parameter 126 *DC braking time*. Note: In parameter 504 *DC brake* a selection is made to define how Bit 02 gates with the corresponding function on a digital input.

Bit 03, Coasting stop:

Bit 03 = '0' causes the frequency converter to immediately "let go" of the motor (the output transistors are "shut off"), so that it coasts to a standstill. Bit 03 = '1' causes the frequency converter to be able start the motor if the other starting conditions have been fulfilled. Note: In parameter 502 *Coasting stop* a selection is made to define how Bit 03 gates with the corresponding function on a digital input.

Bit 04, Quick stop:

Bit 04 = '0' causes a stop, in which the motor's speed is ramped down to stop via parameter 212 *Quick stop ramp-down time*.

Bit 05, Freeze output frequency:

Bit 05 = '0' causes the present output frequency (in Hz) to freeze. The frozen output frequency can now only be changed by means of the digital inputs programmed to *Speed up* and *Speed down*.



If *Freeze output* is active, the frequency converter cannot be stopped via Bit 06 *Start* or via a digital input. The frequency converter can only be stopped by the following:

- Bit 03 Coasting stop
- Bit 02 DC braking
- Digital input programmed to *DC braking*, *Coasting stop* or *Reset and coasting stop*.

Bit 06, Ramp stop/start:

Bit 06 = '0' causes a stop, in which the motor's speed is ramped down to stop via the selected *ramp down* parameter.

Bit 06 = '1' causes the frequency converter to be able to start the motor, if the other starting conditions have been fulfilled. Note: In parameter 505 *Start* a selection is made to define how Bit 06 Ramp stop/start gates with the corresponding function on a digital input.

Bit 07, Reset:

Bit 07 = '0' does not cause a reset.

Bit 07 = '1' causes the reset of a trip. Reset is activated on the signal's leading edge, i.e. when changing from logic '0' to logic '1'.

Bit 08, Jog:

Bit 08 = '1' causes the output frequency to be determined by parameter 213 *Jog frequency*.

Bit 09, Selection of ramp 1/2:

Bit 09 = "0" means that ramp 1 is active (parameters 207/208). Bit 09 = "1" means that ramp 2 (parameters 209/210) is active.

Bit 10, Data not valid/Data valid:

Is used to tell the frequency converter whether the control word is to be used or ignored. Bit 10 = '0' causes the control word to be ignored, Bit 10 = '1' causes the control word to be used. This function is relevant, because the control word is always contained in the telegram, regardless of which type of telegram is used, i.e. it is possible to turn off the control word if you do not wish to use it in connection with updating or reading parameters.

Bit 11, No function:

Bit 11 has no function.

Bit 12, No function:

Bit 12 has no function.

Bit 13/14, Selection of Setup:

Bits 13 and 14 are used to choose from the four menu Setups according to the following table:

Setup	Bit 14	Bit 13
1	0	0
2	0	1
3	1	0
4	1	1

The function is only possible when *Multi-Setups* is selected in parameter 004 *Active Setup*.

Note: I parameter 507 *Selection of Setup* a selection is made to define how Bit 13/14 gates with the corresponding function on the digital inputs.

Bit 15 Reversing:

Bit 15 = '0' causes no reversing.

Bit 15 = '1' causes reversing.

Note: In the factory setting reversing is set to *digital* in parameter 506 *Reversing*. Bit 15 only causes reversing when either *Ser. communication*, *Logic or* or *Logic and* is selected.

The Status Word in Instance 150/151 is defined as following:

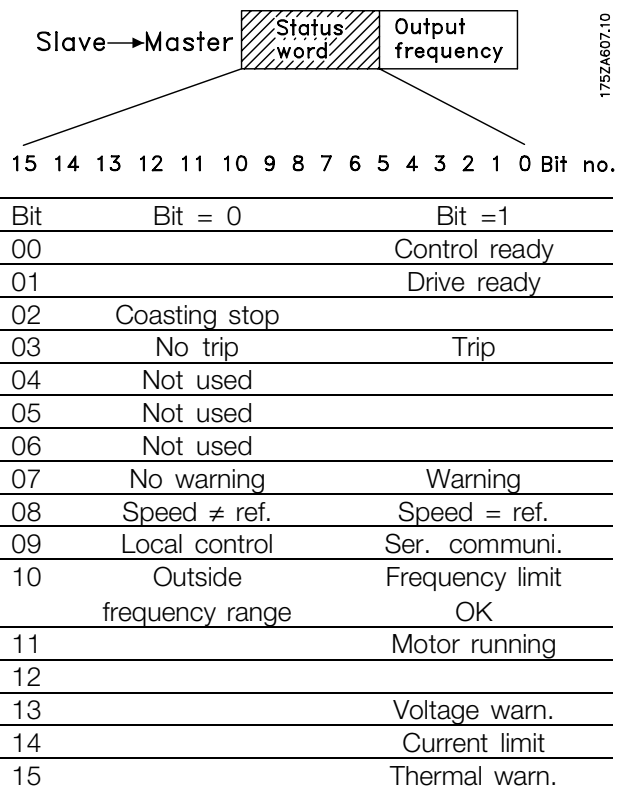
Bit 00, Control ready:

Bit 00 = '1'. The frequency converter is ready for operation.

Bit 00 = '0'. The frequency converter is not ready for operation.

Bit 01, Drive ready:

Bit 01 = '1'. The frequency converter is ready for operation, but there is an active coasting command via the digital inputs or via serial communication.

Bit 02, Coasting stop:

Bit 02 = '0'. The frequency converter has released the motor.

Bit 02 = '1'. The frequency converter can start the motor when a start command is given.

Bit 03, No trip/trip:

Bit 03 = '0' means that the frequency converter is not in fault mode.

Bit 03 = '1' means that the frequency converter is tripped, and that it needs a reset signal for operation to be reestablished.

Bit 04, Not used:

Bit 04 is not used in the status word.

Bit 05, Not used:

Bit 05 is not used in the status word.

Bit 06, Not used:

Bit 06 is not used in the status word.

Bit 07, No warning/warning:

Bit 07 = '0' means that there are no warnings.

Bit 07 = '1' means that a warning has occurred.

Bit 08, Speed \neq ref/speed = ref.:

Bit 08 = '0' means that the motor is running, but that the present speed is different from the preset speed reference. It might, for example, be the case while the speed is being ramped up/down during start/stop.

Bit 08 = '1' means that the motor's present speed is the same as the preset speed reference.

Bit 09, Local operation/serial communication control:

Bit 09 = '0' means that [STOP/RESET] is activated on the control unit, or that *Local control* in parameter 002 *Local/remote operation* is selected. It is not possible to control the frequency converter via serial communication.

Bit 09 = '1' means that it is possible to control the frequency converter via serial communication.

Bit 10, Outside frequency range:

Bit 10 = '0', if the output frequency has reached the value in parameter 201 *Output frequency low limit* or parameter 202 *Output frequency high limit*. Bit 10 = "1" means that the output frequency is within the defined limits.

Bit 11, Running/not running:

Bit 11 = '0' means that the motor is not running.

Bit 11 = '1' means that the frequency converter has a start signal or that the output frequency is greater than 0 Hz.

Bit 13, Voltage warning high/low:

Bit 13 = '0' means that there are no voltage warnings.

Bit 13 = '1' means that the DC voltage in the frequency converter's intermediate circuit is too low or too high.

Bit 14, Current limit:

Bit 14 = '0' means that the output current is less than the value in parameter 221 *Current Limit I_{LIM}*.

Bit 14 = '1' means that the output current is greater than the value in parameter 221 *Current Limit I_{LIM}* and that the frequency converter will trip after a set period of time.

Bit 15, Thermal warning:

Bit 15 = '0' means that there is no thermal warning.

Bit 15 = '1' means that the temperature limit has been exceeded in either the motor, frequency converter or from a thermistor that is connected to a digital input.

■ Bus reference value

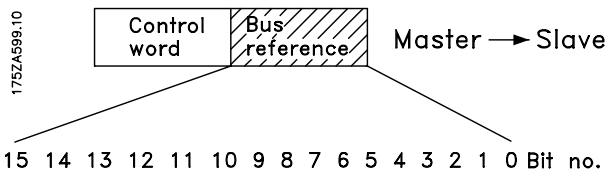

The frequency reference value is transmitted to the VLT frequency converter in the form of a 16-bit word. The value is transmitted as a whole number (-32767 ⇒ 32767). (Negative figures are formatted by means of 2's complement.)

The bus reference has the following format:

- Parameter 203 = "0" ["ref_{MIN} ⇒ ref_{MAX}"]
- 0 ⇒ 16384 (4000 Hex) ~ 0 ⇒ 100% ~ "ref_{MIN} ⇒ ref_{MAX}
- Parameter 203 = "1" [- ref_{MAX} ⇒ + ref_{MAX}]
- 16384 (C000 Hex) ⇒ + 16384 (4000 Hex) ~
- 100% ⇒ + 100% ~ - ref_{MAX} ⇒ + ref_{MAX}

■ Actual output frequency

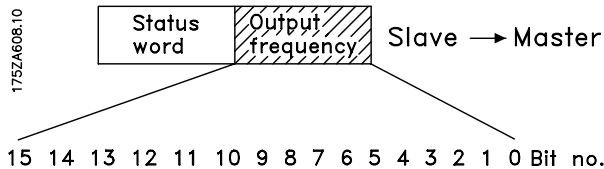

The value of the actual output frequency of the VLT frequency converter, is transmitted in the form of a 16-bit word. The value is transmitted as a whole number (-32767 ⇒ 32767) (Negative figures are formed by means of 2's complement).

The actual output frequency has the following format:

- 32767 ⇒ +32767.
- 16384 (C000 Hex) corresponds to -100%, and
- 16384 (4000 Hex) corresponds to 100%.

■ Process Data, PCD

The VLT 2800/FCD 300 DeviceNet offers a flexible way for the user to customize the number of Process Data (I/O words) and the functionality of each word. To activate the user definable Process data the user has to select the *I/O Instance 101/151* in parameter 904 *PPO selection*. This will change the I/O size to four words in the input and output area. This selection uses the Danfoss specific profile for the Control-/Status word as well for the Main Reference Value/Main Actual Value.

The first two words are fixed on the VLT 2800/FCD 300 DeviceNet, whereas the input and output PCD1

and PCD2 can be selected by the user. The number of PCDs active in a system is fixed to 2 words.



NB!:

The changing of Parameter 904 *PPO selection* is first active at the next powerup, and it may change the mapping of the Masters (PC/PLC).

To enable the use of PCD data of the VLT 2800/FCD 300 DeviceNet the contents of each single PCD word has to be configured in Parameter 915 *PCD write configuration* and 916 *PCD read configuration*. Changing Parameter 915/916 has immediately effect on the PCD data.

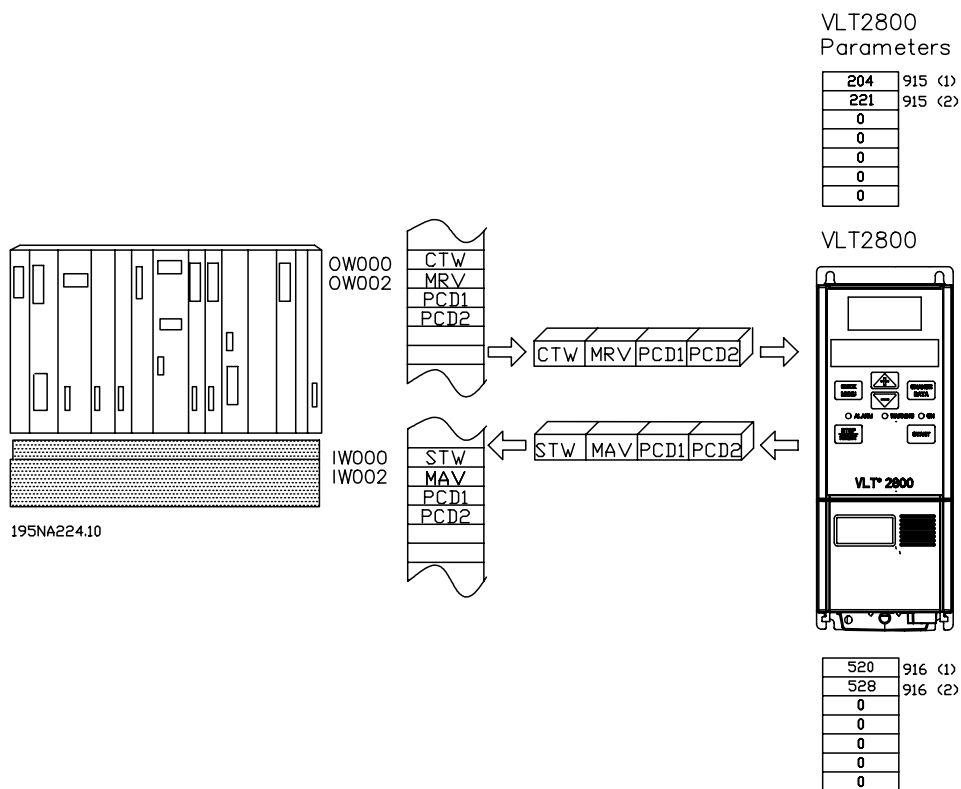

■ DeviceNet object classes

■ Class Code 0x01

For Class Code 0x01, the following Identity Instance Attributes have been implemented:

Attribute	Access	Name	Datatype	Min/Max	Units	Default	Description
1	Get	Vendor	USINT			97	Danfoss Drives Vendor Code
2	Get	Device Type	UINT			2	AC/DC Motor
3	Get	Product Code	UINT	200 - 399 VLT 2800 400 - 499 FCD 300			See EDS File section
4	Get	Revision	UINT				Software version on VLT 2800/FCD 300
5	Get	Status	UINT				
6	Get	Serial number	UDINT				From VLT 2800/FCD 300
7	Get	Product Name	String				VLT 2800/FCD 300
10	Get/Set	Heartbeat Interval	USINT				

■ Class Code 0x02

For Class Code 0x02, the following Message Router Instance Attributes have been implemented:

Attribute	Access	Name	Datatype	Min/Max	Units	Default	Description
1	Get	Number of classes	USINT				

■ Class Code 0x03

For Class Code 0x03, the following DeviceNet Objects have been implemented:

Attribute	Access	Name	Datatype	Min/Max	Units	Default	Description
1	Get/Set	MAC ID	USINT	0-63		63	Node adress
2	Get/Set	Baud Rate	USINT	0-2		0	0 = 125 1 = 250 2 = 500
3	Get/Set	BOI	BOOL				Bus-Off Interrupt
5	Get	Allocate Information					Only required if predefined Master/Slave is implemented
6	Get	MAC ID Switch changed	BOOL	0-1		0	The Node adress Switch has changed since the last power-up/reset
7	Get	Baud Rate switched from last power up	BOOL	0-1		0	Tha Baud Rate Switch has changed since the last power-up/reset

■ **Class Code 0x04**

For Class Code 0x04, the following Assembly Object Instances have been implemented:

Attribute	Access	Name	Datatype	Min/Max	Units	Default	Description
3	Set	Data	ARRAY				

Attribute	Access	Datasize	Description
20	Set	2 Words	DeviceNet AC/DC Profile
21	Set	2 Words	DeviceNet AC/DC Profile
70	Get	2 Words	DeviceNet AC/DC Profile
71	Get	2 Words	DeviceNet AC/DC Profile
100	Set	2 Words	Danfoss specific, no PCD Words
101	Set	4 Words	Danfoss specific, 2 PCD Words
150	Get	2 Words	Danfoss specific, no PCD Words
151	Get	4 Words	Danfoss specific, 2 PCD Words

■ **Class Code 0x05**

For Class Code 0x05, the following Connection Object Attributes have been implemented:

Instance 1 Attributes: Explicit Message Instance

Attribute	Access	Name	Datatype	Description
1	Get	State	USINT	State of the object
2	Get	Instance Type	USINT	Indicates either I/O or Messages Connection
3	Get	Transport Class Trigger	USINT	Defines behaviour of the Connection
4	Get	Produced Connection ID	UINT	CAN Identifier Field when the Connection transmits
5	Get	Consumed Connection ID	UINT	AN Identifier Field value that denotes message to be received
6	Get	Initial Communication Characteristics	USINT	Defines the message group(s) across which productions and consumptions associated with this Connection occur
7	Get	Produced Connection size	UINT	Maximum number of bytes transmitted across this Connection
8	Get	Consumed Connection size	UINT	Maximum number of bytes received across this Connection
9	Get/Set	Expected Package	UINT	Defines timing associated with this Connection
12	Get	Watchdog timeout action	USINT	Defines how to handle Inactivity/Watchdog timeout
13	Get	Produced Connection Path Length	UINT	Number of Bytes in the produced connection path attribute
14	Get	Produced Connection Path	Array of USINT	Specifies the Application Object(s) whose data is to be produced by these Connection Objects
15	Get	Consumed Connection Path Length	UINT	Number of bytes in the consumed connection path attribute
16	Get	Consumed Connection Path	Array of USINT	Specifies the Application object(s) that are to receive the data consumed by this Connection object
17	Get	Production Inhibit Time	UINT	Defines minimum time between new data production. This attribute is required for I/O Client connection

Instance 2 Attributes: Polled I/O

Attribute	Access	Name	Datatype	Description
1	Get	State	USINT	State of the object
2	Get	Instance Type	USINT	Indicates either I/O or Messages Connection
3	Get	Transport Class Trigger	USINT	Defines behaviour of the Connection
4	Get	Produced Connection ID	UINT	CAN Identifier Field when the Connection transmits
5	Get	Consumed Connection ID	UINT	AN Identifier Field value that denotes message to be received
6	Get	Initial Communication Characteristics	USINT	Defines the message group(s) across which productions and consumptions associated with this Connection occur
7	Get	Produced Connection size	UINT	Maximum number of bytes transmitted across this Connection
8	Get	Consumed Connection size	UINT	Maximum number of bytes received across this Connection
9	Get/Set	Expected Package	UINT	Defines timing associated with this Connection
12	Get	Watchdog timeout action	USINT	Defines how to handle Inactivity/Watchdog timeout
13	Get	Produced Connection Path Length	UINT	Number of Bytes in the produced connection path attribute
14	Get	Produced Connection Path	Array of USINT	Specifies the Application Object(s) whose data is to be produced by these Connection Objects
15	Get	Consumed Connection Path Length	UINT	Number of bytes in the consumed connection path attribute
16	Get	Consumed Connection Path	Array of USINT	Specifies the Application object(s) that are to receive the data consumed by this Connection object
17	Get	Production Inhibit Time	UINT	Defines minimum time between new data production. This attribute is required for I/O Client connection

Instance 3: Bit Strobe

Attribute	Access	Name	Datatype	Description
1	Get	State	USINT	State of the object
2	Get	Instance Type	USINT	Indicates either I/O or Messages Connection
3	Get	Transport Class Trigger	USINT	Defines behaviour of the Connection
4	Get	Produced Connection ID	UINT	CAN Identifier Field when the Connection transmits
5	Get	Consumed Connection ID	UINT	AN Identifier Field value that denotes message to be received
6	Get	Initial Communication Characteristics	USINT	Defines the message group(s) across which productions and consumptions associated with this Connection occur
7	Get	Produced Connection size	UINT	Maximum number of bytes transmitted across this Connection
8	Get	Consumed Connection size	UINT	Maximum number of bytes received across this Connection
9	Get/Set	Expected Package	UINT	Defines timing associated with this Connection
12	Get	Watchdog timeout action	USINT	Defines how to handle Inactivity/Watchdog timeout
13	Get	Produced Connection Path Length	UINT	Number of Bytes in the produced connection path attribute
14	Get	Produced Connection Path	Array of USINT	Specifies the Application Object(s) whose data is to be produced by these Connection Objects
15	Get	Consumed Connection Path Length	UINT	Number of bytes in the consumed connection path attribute
16	Get	Consumed Connection Path	Array of USINT	Specifies the Application object(s) that are to receive the data consumed by this Connection object
17	Get	Production Inhibit Time	UINT	Defines minimum time between new data production. This attribute is required for I/O Client connection

Instance 4: Change of State/Cycle

Attribute	Access	Name	Datatype	Description
1	Get	State	USINT	State of the object
2	Get	Instance Type	USINT	Indicates either I/O or Messages Connection
3	Get	Transport Class Trigger	USINT	Defines behaviour of the Connection
4	Get	Produced Connection ID	UINT	CAN Identifier Field when the Connection transmits
5	Get	Consumed Connection ID	UINT	AN Identifier Field value that denotes message to be received
6	Get	Initial Communication Characteristics	USINT	Defines the message group(s) across which productions and consumptions associated with this Connection occur
7	Get	Produced Connection size	UINT	Maximum number of bytes transmitted across this Connection
8	Get	Consumed Connection size	UINT	Maximum number of bytes received across this Connection
9	Get/Set	Expected Package	UINT	Defines timing associated with this Connection
12	Get	Watchdog timeout action	USINT	Defines how to handle Inactivity/Watchdog timeout
13	Get	Produced Connection Path Length	UINT	Number of Bytes in the produced connection path attribute
14	Get	Produced Connection Path	Array of USINT	Specifies the Application Object(s) whose data is to be produced by these Connection Objects
15	Get	Consumed Connection Path Length	UINT	Number of bytes in the consumed connection path attribute
16	Get	Consumed Connection Path	Array of USINT	Specifies the Application object(s) that are to receive the data consumed by this Connection object
17	Get	Production Inhibit Time	UINT	Defines minimum time between new data production. This attribute is required for I/O Client connection

■ Class Code 0x28

For Class Code 0x28, the following Motor Data Instance Attributes have been implemented:

Attribute	Access	Name	Datatype	Min/Max	Units	Default	Description
3	Get/Set	MotorType	USINT	0-10		7	0 = Non Standard Motor 1 = PM DC Motor 2 = FC DC Motor 3 = PM Synchronous Motor 4 = FC Synchronous Motor 5 = Switched Reluctance Motor 6 = Wound Rotor Induction Motor 7 = Squirrel Cage Induction Motor 8 = Stepper Motor 9 = Sinusoidal PM BL Motor 10 = Trapezoidal PM BL Motor
6	Get/Set	Rated Current	UNIT	0-100.00	100 mA	Drive depend	Rates Stator Current (from Motor nameplate)
7	Get/Set	Rated Voltage	UNIT	200-500	Volt	Drive depend	Rated Base Voltage (from Motor nameplate)
8	Get/Set	Rated power	UDINT	0-18500	Watt	Drive depend	Rated Power at Rated Frequency
9	Get/Set	Rated Frequency	UNIT	1-1000	Hz	Drive depend	Rated Elec. Frequency (from Motor nameplate)
15	Get/Set	Base Speed	UNIT	100-60000	RPM	Drive depend	Nominal Motor speed (from Motor nameplate)

■ Class Code 0x29

For Class Code 0x29, the following Control Supervisory Instance Attributes have been implemented:

Attribute	Access	Name	Datatype	Min/Max	Default	Description
3	Get/Set	Run 1	Bool	0-1		Run Fwd, see note below
4	Get/Set	Run 2	Bool	0-1		Run rev, see note below
5	Get/Set	NetCtrl	Bool	0-1	1	0 = Local Control 1 = Control from Network
6	Get	State	USINT	0-7		0 = Vendor Specific 1 = Startup 2 = Not ready 3 = Ready 4 = Enabled 5 = Stopping 6 = Fault Stop 7 = Fault
7	Get	Running 1	Bool	0-1	0	0 = Other State 1 = (Enable and Run 1) or (Stopping and Running 1) or (Fault stop and Running 1)
8	Get	Running 2	Bool	0-1	0	0 = Other State 1 = (Enable and Run 2) or (Stopping and Running 2) or (Fault stop and Running 2)
9	Get	Ready	Bool	0-1		0 = Other State 1 = Ready or Enabled or Stopping
10	Get	Fault	Bool	0-1		0 = No Faults Present 1 = Fault Occured (latched)
12	Get/Set	Fault Rst	Bool	0-1	0	0 = No Action 0 → 1 = Reset Fault
13	Get	Fault Code	UINT			
15	Get	Crt From Net	Bool	0-1	1	0 = Control is local 1 = Control is from Network
16	Get/Set	DN Fault Mode	USINT	0-2	1	Action on loss of DeviceNet 0 = Fault + Stop 1 = Ignore (Warning Optional) 2 = Danfoss specific

AC drive profile is only available if selecting Instance 20/70 or 21/71

■ Class Code 0x2A

For Class Code 0x2A, the following AC/DC Drive Instance Attributes have been implemented:

Attribute	Access	Name	Datatype	Min/Max	Default	Description
3	Get	At Reference	Bool	0-1		0 = Drive not at reference 1 = Drive actual at reference
4	Get/Set	Net Ref	Bool	0-1	1	0 = Set reference not DN Control 1 = Set Reference at DN Control
6	Get/Set	Drive Mode	USINT	0-5	1	0 = Vendor specific mode 1 = Open loop speed (Frequency) 2 = Closed loop speed control 3 = Torque control 4 = Process control (e.g. PI) 5 = Position control
7	Get	Speed Actual	INT		RPM / 2 Speed Scale	Actual drive speed (best approximation)
8	Get/Set	Speed Ref	INT		RPM / 2 Speed Scale	Speed Reference
22	Get/Set	Speed Scale	SINT	-128 - 127		Speed scaling factor
29	Get	Ref from Net	Bool	0-1		0 = Local speed reference 1 = DeviceNet speed reference

■ Danfoss Classes

Parameter 001 - 099	Class 100
Parameter 101 - 199	Class 101
Parameter 200 - 299	Class 102
Parameter 300 - 399	Class 103
Parameter 400 - 499	Class 104
Parameter 500 - 599	Class 105
Parameter 600 - 699	Class 106
Parameter 700 - 799	Class 107
Parameter 800 - 899	Class 108
Parameter 900 - 999	Class 109
Index Pointer	Class 120

Instance Description:

The Danfoss VLT 2800/FCD 300 DeviceNet only use Instance 1, so always leave this at the value of 1.

Attribute Description:

The attributes for the VLT 2800/FCD 300 parameter are the last 2 (two) digits of the parameter + 100.

Example:

The parameter 529 (Analog input, terminal 53) will have the following:

Class	105
Instance	1
Attribute	129

Reading/writing to parameters with index:

Parameters of type indexed (e.g. 915 & 916) need special handling since DeviceNet does not support indexed addressing.

The way to handle this in the VLT 2800/FCD 300, is by using the the Danfoss Class 120. which serves as an index pointer. The pointer has to be set up before every read/write of an indexed parameter.



NB!:

If two masters are accessing this feature at the same ime, wrong data may occur.

Example:

Write 518 in index 2 in parameter 916 *PCD Read*:

First setup the index pointer in class 120. In this example index 2:

Class	Instance	Attribute	Variable
120 Dec	1 Dec	100 Dec	2 Dec
78 Hex	1 Hex	64 Hex	2 hex

Next step is to write the data (in this example 518) to parameter 916 *PCD Read*

Class	Instance	Attribute	Variable
109 Dec	1 Dec	116 Dec	518 Dec
6D Hex	1 Hex	74 Hex	206 hex

■ DeviceNet Operation Mode

■ Bit Strobe

Bit strobe provides the ability of a slave to react to a special command of the master in a defined way. Master sends the Bit strobe command to many devices at a time, only one bit of the message is assigned to a single slave at a time, what means, that only the state "TRUE" or "FALSE" can be transmitted.

This parameter may be used for synchronizing drives. Executing the Bit-Strobe command with a value of "1" (TRUE) leads the addressed drive to ignore the input values of the control word and the reference transmitted via the Assembly Instances, the Control Supervisor and the AC/DC Drive Object. If the Bit-Strobe command is executed with a value of "0"

(FALSE), the drive reacts according to the input values again. This means, that the value of the Bit-Strobe command is stored internally and the drive reacts according the value of the Bit-Strobe command. The master can transmit the new reference when the Bit-Strobe value is "1", it must be valid after the execution of the Bit-Strobe command with the value "0" [10]. After a Bit-Strobe command has been executed, the device must answer with the according I/O telegram and ignore any CTW, MAV and PCDs transmitted by the master.

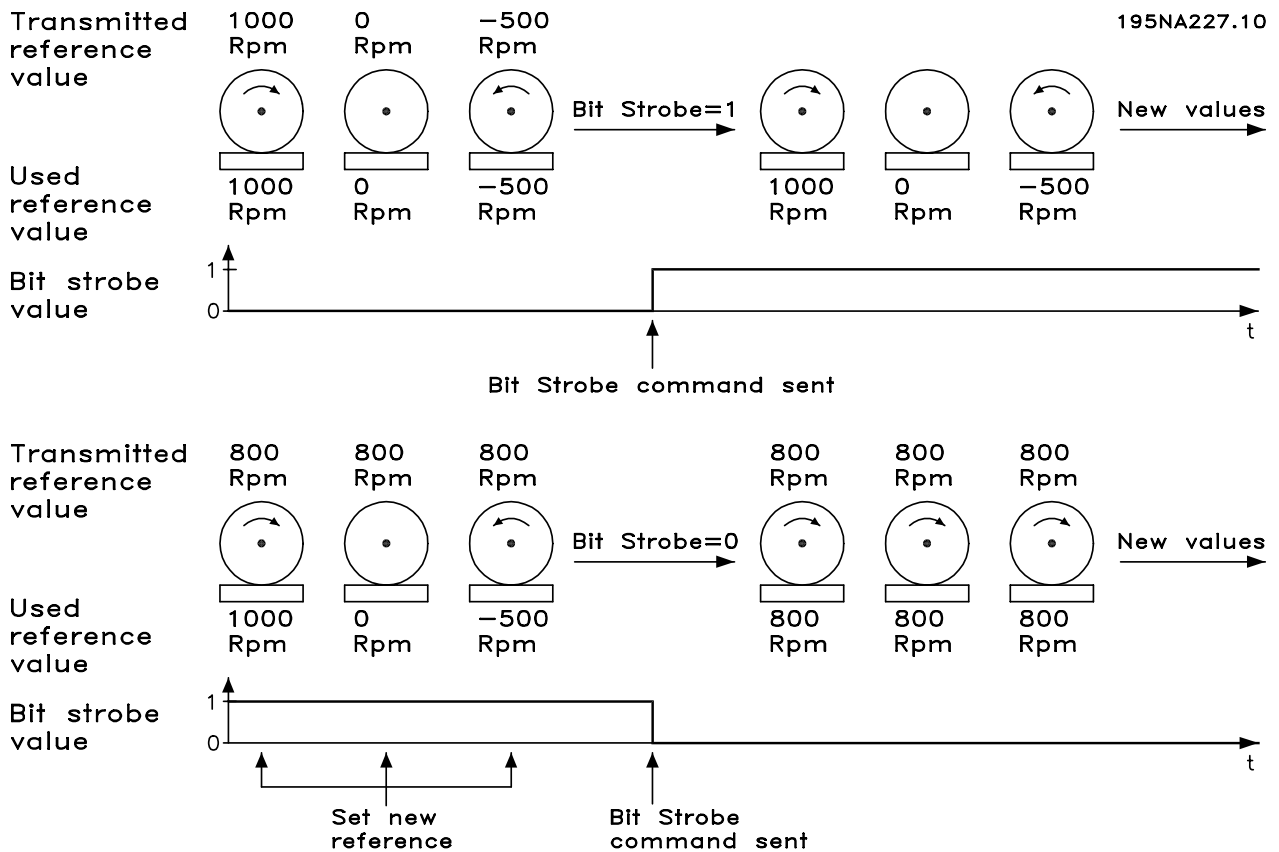

■ **Polling**

This is the standard Devicenet operation mode, meaning that data can be acquired by the master via polling using the Devicenet or Danfoss objects.

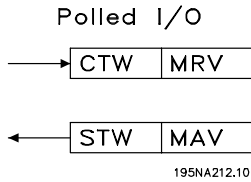

■ **Change of State, COS**

This operation modus can be used in order to minimize network traffic. Messages are only sent to the consumer, if a defined state or value has changed. In order to signalize, that the connection has not been crashed or is powered off, a Heartbeat Message is transmitted within a specified time (Heartbeat Interval). This time is defined in attribute heartbeat time of the connection object class code 0x05. To prevent the device from producing heavy network traffic, if a value often changes, the Production Inhibit Time (attribute of connection object) is defined. This parameter defines the minimum delay between 2 c-o-s messages. The Attribute Expected Package Rate defines the maximum time between two Cos messages even though the value has not changed. Cos operation modus can only be used on I/O instances defined in parameter 904.

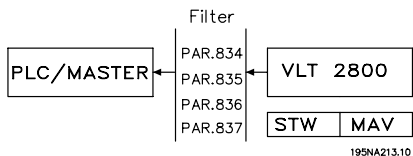
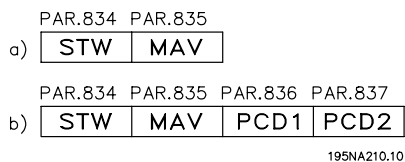

Parameters 834 through 837 can be used for filtering out undesired events for Cos. If a filter bit is set to 0, the corresponding I/O instance bit will not be able to produce a Cos message.

■ EDS Files

Note that the EDS files can be uploaded from the VLT frequency converters via RS Networkx. Before uploading the EDS file you must check the version of RS Networkx in Help and About RS Networkx. RS Networkx version 3.11.00 supports the format Errata 2 and no changes must be made to the VLT frequency converter. RS Networkx version 3.00.00 supports Errata 1 and parameter 838 *EDS Data type* must be set to Errata 1 and power must be re-cycle.

Start RS Networkx and go online and the VLT 2800/FCD 300 will be shown as a grey box as *unregistered device*. Click on the VLT 2800/FCD 300 and go to *Tools* and choose *EDS Wizard*. Click on next by the EDS wizard and choose *Create an EDS file*. RS Networkx will now start to create an EDS file from the VLT frequency converter. To upload EDS files please visit www.DanfossDrives.com

VLT 2800 US version with DeviceNet

Product Code	Drive Model	Drive Rating kW (HP)	Voltage	EDS File Name
232	VLT 2803	0.37 (0.50)	200 - 240 V	
233	VLT 2805	0.55 (0.75)	200 - 240 V	
234	VLT 2807	0.75 (1.00)	200 - 240 V	
235	VLT 2811	1.10 (1.50)	200 - 240 V	
236	VLT 2815	1.50 (2.00)	200 - 240 V	
237	VLT 2822	2.20 (3.00)	200 - 240 V	
238	VLT 2830	3.70 (5.00)	200 - 240 V	
283	VLT 2805	0.55 (0.75)	380 - 480 V	
284	VLT 2807	0.75 (1.00)	380 - 480 V	
285	VLT 2811	1.10 (1.50)	380 - 480 V	
286	VLT 2815	1.50 (2.00)	380 - 480 V	
287	VLT 2822	2.20 (3.00)	380 - 480 V	
288	VLT 2830	3.00 (4.00)	380 - 480 V	
289	VLT 2840	4.00 (5.00)	380 - 480 V	
290	VLT 2855	5.50 (7.50)	380 - 480 V	
291	VLT 2875	7.50 (10.00)	380 - 480 V	
292	VLT 2880	11.0 (15.00)	380 - 480 V	
293	VLT 2881	15.0 (20.00)	380 - 480 V	
294	VLT 2882	18.5 (25.00)	380 - 480 V	



VLT® 2800 / FCD 300 DeviceNet

VLT 2800 European version with DeviceNet

Product Code	Drive Model	Drive Rating kW (HP)	Voltage	EDS File Name
332	VLT 2803	0.37 (0.50)	200 - 240 V	
333	VLT 2805	0.55 (0.75)	200 - 240 V	
334	VLT 2807	0.75 (1.00)	200 - 240 V	
335	VLT 2811	1.10 (1.50)	200 - 240 V	
336	VLT 2815	1.50 (2.00)	200 - 240 V	
337	VLT 2822	2.20 (3.00)	200 - 240 V	
338	VLT 2830	3.70 (5.00)	200 - 240 V	
383	VLT 2805	0.55 (0.75)	380 - 480 V	
384	VLT 2807	0.75 (1.00)	380 - 480 V	
385	VLT 2811	1.10 (1.50)	380 - 480 V	
386	VLT 2815	1.50 (2.00)	380 - 480 V	
387	VLT 2822	2.20 (3.00)	380 - 480 V	
388	VLT 2830	3.00 (4.00)	380 - 480 V	
389	VLT 2840	4.00 (5.00)	380 - 480 V	
390	VLT 2855	5.50 (7.50)	380 - 480 V	
391	VLT 2875	7.50 (10.00)	380 - 480 V	
392	VLT 2880	11.0 (15.00)	380 - 480 V	
393	VLT 2881	15.0 (20.00)	380 - 480 V	
394	VLT 2882	18.5 (25.00)	380 - 480 V	

FCD 300 European version with DeviceNet

Product Code	Drive Model	Drive Rating kW (HP)	Voltage	EDS File Name
480	FCD 303	0.37 (0.50)	380 - 480 V	
481	FCD 305	0.55 (0.75)	380 - 480 V	
482	FCD 307	0.75 (1.00)	380 - 480 V	
483	FCD 311	1.10 (1.50)	380 - 480 V	
484	FCD 315	1.50 (2.00)	380 - 480 V	
485	FCD 322	2.20 (3.00)	380 - 480 V	
486	FCD 330	3.00 (4.00)	380 - 480 V	

■ Special Attention



NB!:

Please note, that terminal 46 has been removed from the VLT 2800 DeviceNet card, meaning that parameter 341 - 342 are not having any function.

- 002:
If operation site = Local, then control via DeviceNet is not possible.
- 502-508:
Selection of how to gate DeviceNet control commands with control commands on the digital inputs of the control card.
- 515-538:
Data read out parameters that can be used to read various actual data from the VLT, as for example actual status on the analog and digital inputs of the control card thus using these as inputs to the master.
- 800 *Protocol Select*
Select DeviceNet in this parameter.
- 801 *Baud rate select*
Selection of DeviceNet transmission speed.
- 833 *Fieldbus enable*
Enable the DeviceNet communication. The default setting is disable.
- 904 *PPO selection*
Selection of Instance type.
- 918 *Station address / MAC ID*
Set the Station address / MAC ID in this parameter.

620 Operation Mode

(OPERATION MODE)

Value:

★Normal operation (NORMAL OPERATION)	[0]
Control card test (CONTROL CARD TEST)	[2]
Initialize (INITIALIZE)	[3]

Function:

In addition to its normal function, this parameter can be used to test the control card. There is also the opportunity to perform an initialisation at the factory setting for all parameters in all Setups, with the exception of parameters 500 *Address*, 501 *Baudrate*, 600-605 *Operating data* and 615-617 *Fault log*.

★ = factory setting. () = display text [] = value for use in communication via serial communication port

Description of choice:

For FCD 300 connections see FCD 300 Design Guide MG.04.AX.YY par. 620.

Normal function [0] is used for normal operation of the motor.

Control card test [2] is selected if you wish to check the control card's analog/digital input, analog/digital outputs, relay outputs and 10 V and 24 V voltages. The test is performed as follows:

- 18, 27, 33 are connected to relay terminal 03.
- 19, 29, V+ are connected to relay terminal 02.
- 50 - 53 are connected.
- 42 - 60 are connected.
- 55 - V- are connected.
- 12 is connected to relay terminal 01.

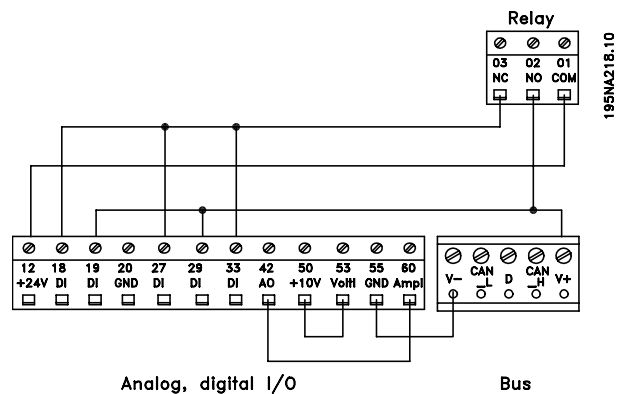

- Use the following procedure for the control card test:
1. Select control card test.
 2. Disconnect the mains voltage and wait until the light in the display has disappeared.
 3. Mount according to drawing and description.
 4. Connect the mains voltage.
 5. The frequency converter automatically undertakes a test of the control card.

If the frequency converter displays a fault code from 37-45, the control card test has failed. Replace the control card to start up the frequency converter. If the frequency converter comes into Display mode, the test is OK. Remove the test connector and the frequency converter is ready for operation. Parameter 620 *Operating mode* is automatically set to *Normal operation* [0].

Initialisation [3] is selected if you wish to use the unit's factory setting.

Procedure for initialisation:

1. Select *Initialisation* [3].
2. Disconnect the mains voltage and wait until the light in the display has disappeared.
3. Connect the mains voltage.
4. An initialisation is performed in all parameters in all Setups, with the exception of parameters

500 Address, 501 Baudrate, 600-605 Operating data, 615-617 Fault log, 833 Fieldbus enable and 904 PPO selection.

800 Protocol Select (PROTOCOL SELECT)

Value:

★DeviceNet (DEVICENET) [2]

Function:

This parameter is read only.

801 Baud Rate Select (BAUD RATE SELECT)

Value:

★125 kbps (125 KBPS) [20]
250 kbps (250 KBPS) [21]
500 kbps (500 KBPS) [22]

Function:

Selection of the DeviceNet transmission speed. It must correspond to the transmission speed of the master and the other DeviceNet nodes.

Description of choice:

Select the baud rate.



NB!:

Note that a change of this parameter is first executed at next power up.

803 Bus time out (BUS TIME OUT)

Value:

1 - 99 sec ★ 1 sec

Function:

If the VLT frequency converter doesn't receive a control word for a period longer than the time set in this parameter, the function selected in parameter 804 *Response after bus error* will be activated.

Description of choice:

Set the desired time.

Please note, that when the drive is running Cyclic or COS mode, the Bus time out has to be set higher than Heartbeat Rate. If not, the VLT will time out.

804 Bus time out function (TIME OUT FUNCT.)

Value:

★OFF (OFF) [0]
Freeze output frequency (FREEZE OUTPUT) [1]
Stop with auto restart (STOP) [2]
Output = jog frequency (JOGGING) [3]
Output = max speed (MAX SPEED) [4]
Stop with trip (STOP AND TRIP) [5]
Select Setup 2 (SELECT SETUP 2) [8]

Function:

The timeout counter is activated at the first receipt of a valid control word, i.e. bit 10 = OK.

Description of choice:

The VLT remains in the timeout status until one of the following four conditions occurs.

1. A valid control word (bit 10 = OK) is received and control via DeviceNet is resumed with the current control word. If the timeout function *Stop with trip* is selected a reset via bus, terminals or control panel is necessary.
2. Parameter 002 = Local operation => local control through control panel is active.
3. Parameter 804 = Off => control via DeviceNet is resumed, with the control word used last being taken.

805 Bit 10 function (BIT 10 FUNCTION)

Function:

This parameter is read only.

832 Bus Off Interrupt Behavior (BUS OFF INT. BEH)

Value:

★Hold the device in bus-off state (HOLD CAN) [0]
Reset the device and continue communicating (RESET CAN) [1]

Function:

This parameter defines the VLT 2800/FCD 300 behavior if a bus-off interrupt is detected.

Description of choice:

If this parameter is set to *Hold the device in bus-off state* [0] and a bus-off event is detected, the VLT 2800/FCD 300 will go into reset/bus-off state.

★ = factory setting. () = display text [] = value for use in communication via serial communication port

If this parameter is set to *Reset the device and continue communicating* [1] and a bus-off event is detected the VLT 2800/FCD 300 will try to reset and re-initialise the CAN chip and to continue communication.

**833 Fieldbus enable
(FIELDBUS ENABLE)**
Value:

★ Disabled (DISABLE) [0]
Enabled (ENABLE) [1]

Function:

This parameter allows to disable the communication interface.

Description of choice:

Select *Enable* [1] to start the DeviceNet communication.

If *Disable* [0] is selected no communication warning will appear, since the communication interface is disabled.

NB!:

Note that a change of this parameter is first executed at next power up.

**834 Filter Mask for status word
(COS FILTER 1)**
Value:

0000 - FFFF Hex ★ FFFF Hex

Function:

When operating in COS (Change-Of-State) it is possible to filter out bits in the status word that should not be send if they changes.

Description of choice:

Setup the filter mask for the status word.

NB!:

For further information, see the section *Change of state, Cos*.

**835 Filter Mask for main actual value
(COS FILTER 2)**
Value:

0000 - FFFF Hex ★ FFFF Hex

Function:

When operating in COS (Change-Of-State) it is possible to filter out bits in the Main actual value that should not be send if they changes.

Description of choice:

Setup the filter mask for the Main actual value.

**836 Filter Mask PCD 1
(COS FILTER 3)**
Value:

0000 - FFFF Hex ★ FFFF Hex

Function:

When operating in COS (Change-Of-State) it is possible to filter out bits in PCD 1 that should not be send if they changes.

Description of choice:

Setup the filter mask for PCD 1.

**837 Filter Mask PCD 2
(COS FILTER 4)**
Value:

0000 - FFFF Hex ★ FFFF Hex

Function:

When operating in COS (Change-Of-State) it is possible to filter out bits in PCD 2 that should not be send if they changes.

Description of choice:

Setup the filter mask for PCD 2.

**838 EDS Data Types
(EDS DATA TYPES)**
Value:

Errata 1 (ERRATA 1) [0]
★ Errata 2 (ERRATA 2) [1]

Function:

In this parameter it is possible to select between two data types when uploading an EDS file from the VLT frequency converter. The current versions of the configuration tools like DeviceNet Manager and RS Networkx can only handle data type Errata 1.

Description of choice:

Select Errata 1 if DeviceNet Manager or RS Networkx version 3.00 is used.

Select Errata 2 if DeviceNet Manager or RS Networkx version 3.11 or higher is used.

★ = factory setting. () = display text [] = value for use in communication via serial communication port

850 Readout Transmit Error Counter
(R.OUT.TR.ERR.CO.)
Function:

This parameter is a read out of the *Transmit Error Counter* of the CAN controller since the last power up.

851 Readout Receive Error Counter
(R.OUT.RE.ERR.CO.)
Function:

This parameter is a read out of the *Receive Error Counter* of the CAN controller since the last power up.

852 Readout Bus Off Counter
(R.OUT.BUS.OFF.CO)
Function:

This parameter is a read out of the how many Bus Off events there has been since the last power up.

860 Controlword
(CONTROLWORD)
Function:

This parameter is a read out of the VLT frequency Control word. This parameter can only be read via standard bus or DeviceNet and is not available via LCP.

861 Reference Value
(REFERENCE VALUE)
Function:

This parameter is a read out of the VLT frequency Reference value in the range 0 - 4000 Hex. This parameter can only be read via standard bus or DeviceNet and is not available via LCP.

880 Statusword
(STATUSWORD)
Function:

This parameter is a read out of the VLT frequency Status word. This parameter can only be read via standard bus or DeviceNet and is not available via LCP.

881 Main Actual Value
(MAIN ACTUAL VAL.)
Function:

This parameter is a read out of the VLT frequency Main Actual Value in the range of 0 - 4000 Hex. This parameter can only be read via standard bus or DeviceNet and is not available via LCP.

904 PPO selection
(PPO TYPE SELECT)
Value:

Instance 20/70 (INSTANCE 20/70)	[10]
Instance 21/71 (INSTANCE 21/71)	[11]
★Instance 100/150 (INSTANCE 100/150)	[12]
Instance 101/151 (INSTANCE 101/151)	[13]

Function:

This parameter allows to select between four different instances for the data transmission.

Instances 100/150 and 101/151 is a Danfoss specific instance and instance 20/70 and 21/71 is a ODVA specific AC Drive profile.

See also *Drive profile* in this manual for further information.

NB!:

Note that a change of this parameter is first executed at next power up.

Description of choice:

Instance 100/150 use 2 words - one word for the control word and one word for the reference. See the control word in *Control word and Status word under instance 100/150* in this manual.

Instance 101/151 use 4 words - one word for the control word and one word for the reference. The last two words (PCD1 and PCD2) are user definable where it is possible to read and write to parameters via I/O communication. By using PCD to read data from parameters in the VLT it will be must quicker update than explicit message. See the control word in *Control word and Status word under instance 100/150* in this manual

Instance 20/70 use 2 words - one word for the control word and one word for the reference. See the control word in *Control word and Status word under instance 20/70* in this manual.

Instance 21/71 use 2 words - one word for the control word and one word for the reference. See the control word in *Control word and Status word under instance 21/71* in this manual.

NB!:

Note that AC Drive profile is only available if selecting Instance 20/70 or 21/71.

915 PCD write configuration
(PCD CONFIG WRITE)
Value:

Sub index 1 (PCD 1)	[Parameter number]
Sub index 2 (PCD 2)	[Parameter number]

Function:

Different parameters can be assigned to PCD 1-2 if instance 101/151 is selected in parameter 904 *PPO Selection*. The values in PCD 1-2 will be written to the selected parameters in the form of data values.

Description of choice:

The sequence of the subindexes corresponds to the sequence of the PCD in the PPO, i.e. subindex 1 = PCD 1, subindex 2 = PCD 2 etc. Each subindex may contain the number of any VLT parameter.

Note that subindex 3 - 8 are having no function.

916 PCD read configuration
(PCD CONFIG READ)
Value:

Sub index 1 (PCD 1)	[Parameter number]
Sub index 2 (PCD 2)	[Parameter number]

Function:

Different parameters can be assigned to PCD 1-2 if instance 101/151 is selected in parameter 904 *PPO Selection*. The values in PCD 1-2 will be read from the selected parameters in the form of data values.

Description of choice:

The sequence of subindices corresponds to the sequence of the PCD in the PPO, i.e. subindex 1 = PCD 1, subindex 2 = PCD 2 etc. Each subindex may contain the number of any VLT parameter.

Note that subindex 3 - 8 are having no function.

918 Station address/MAC ID
(STATION ADDRESS)
Value:

0 - 63	★ 63
--------	------

Function:

Every station connected to the same DeviceNet network must have an unambiguous address.

★ = factory setting. () = display text [] = value for use in communication via serial communication port

Description of choice:

Set a unique address for each VLT 2800/FCD 300 that are connected to the same DeviceNet network.

NB!:

Note that a change of this parameter is first executed at next power up.

953 Warning messages
(WARNING PARAM.)
Value:

0 - FFFF Hex

Function:

In this parameter it is possible to read out warning messages via standard bus or DeviceNet. This parameter is not available via LCP, but the warning message can be seen by choosing *Com warning word* as display readout.

A bit is assigned to every warning (see the following list).

Bit	Status
0	Bus not active (only if the bus has been active for at least once since last power-up)
1	Explicit connection timeout
2	I/O connection timeout
3	Error Passive Receive
4	Error Warning Receive
5	CAN bus off
6	I/O send error
7	Initialisation error
8	No bus supply
9	Bus reset
10	Error Passive Transmit
11	Error warning Transmit
12	Duplicate MAC ID Error
13	RX queue overrun
14	TX queue overrun
15	CAN overrun

Bus not active: means, that no bus communication is present or that the slave is not allocated.

Explicit connection timeout: This bit is set, if an explicit connection is timed out.

I/O connection timeout: This bit is set, if an I/O connection is timed out.

Error Passive Receive: This bit is set, if the CAN controller has reached its error passive state for the message receiver.

Error Warning Receive: This bit is set, if the CAN controller has reached its error warning state (more than 96 receive errors) for the message receiver.

CAN bus off: This bit is set, if CAN bus has been switched off, because a receive or Transmission Error Counter exceed a value of 255 or a bus off interrupt has occurred.

I/O send error: This bit is set, if an I/O send error has been detected.

Initialisation error: This bit is set, if the CAN controller has failed to initialize.

No bus supply: This bit is set, if the DN bus supply (normally 24 V) is not available. Only set, if DN option is active, and not, if CanOpen is active.

Bus reset: This bit is set, if the DN communication has been reset.

Error Passive Transmit: This bit is set, if the bus state error passive for the transmitter is reached. Please refer to chapter 5.8.

Error warning Transmit: This bit is set, if transmit error counter exceeds a value of 96, signaling that the bus may be seriously damaged.

Duplicate MAC ID Error: This bit is set, if duplicate MAC ID has been detected.

RX queue overrun: This bit is set, if receive data buffer has been overrun.

TX queue overrun: This bit is set, if transmit data buffer has been overrun

CAN overrun: This bit is set, if CAN data buffer has been overrun.

967 Control Word
(CONTROL WORD)
Value:

16 bit binary code

Function:

Parameter 967 is dedicated to sending a control word to the VLT frequency converter when using explicit message. This parameter is not available via LCP.

968 Status Word
(STATUS WORD)
Value:

Read only (16 bit binary code)

Function:

Parameter 968 is dedicated to read the status word from the VLT frequency converter when using explicit message. This parameter is not available via LCP.

970 Parameter setup selection
(EDIT SETUP SELECT)
Value:

Factory setting ()	[0]
Parameter setup 1 (SETUP 1)	[1]
Parameter setup 2 (SETUP 2)	[2]
Parameter setup 3 (SETUP 3)	[3]
Parameter setup 4 (SETUP 4)	[4]
★Active set up (ACTIVE SETUP)	[5]

Function:

Like parameter 005 (described in the product manual for the VLT 2800 series).

Description of choice:

It is only possible to write to the active set-up via DeviceNet in the VLT 2800/FCD 300. This means that it is **not** possible to run for instance in set-up 1 and change data in set-up 2, 3 or 4.

971 Save date values
(STORE DATA VALUE)
Value:

★Not active (OFF)	[0]
Save active setup (STORE ACTIVE SETUP)	[1]
Save edit setup (STORE EDIT SETUP)	[2]
Save all setups (STORE ALL SETUPS)	[3]

Function:

Parameter values modified through DeviceNet are only saved in RAM, i.e. the modifications are lost in the event of a power failure. This parameter is used to activate a function by means of which all parameter values are saved in EEPROM, preserving them even in the case of a power failure.

Description of choice:

- *Not active:* The function is not active.
- *Save active setup:* All parameter setups of the active setup are saved in EEPROM. The

value returns to Not active after all parameter values have been saved.

- *Save edit setup:* All parameter setups of the setup being processed are saved in EEPROM. The value returns to Not active after all parameter values have been saved.
- *Save all setups:* All parameter setups in all setups are saved in EEPROM. The value returns to Not active after all parameter values have been saved.

980–982 Defined parameters
(DEFINED PARAM.)
Value:

Read only

Function:

The three parameters contain a list of all parameters defined in the VLT. Each of the three parameters can be read as an array by means of a explicit message.

Each parameter contains up to 116 elements (parameter numbers). The number of parameters that are in use (980, 981 and 982) depends on the respective VLT configuration.

When a 0 is issued as a parameter number, the list ends.

990–992 Modified parameters
(MODIFI. PARAM.)
Value:

Read only

Function:

The three parameters contain a list of all parameters that have been changed from the factory setting. Every one of the three parameters can be read as an array with the help of the explicit read service. The subindices begin with 1 and follow the sequence of the parameter numbers. Each parameter contains up to 116 elements (parameter numbers). The number of parameters that are in use (990, 991 and 992) depends on how many parameters have been modified in comparison with the factory setting.

Pure read parameters (Read only), such as data output parameters, are not logged as modified even if they are changing.

When a 0 is issued as a parameter number, the list ends.

★ = factory setting. () = display text [] = value for use in communication via serial communication port

■ Warning and Alarm Messages

■ Warning and Alarm Messages

There is a clear distinction between alarms and warnings. In the case of an alarm, The VLT will enter a fault condition. After the cause for the alarm has been cleared, the master will have to acknowledge the alarm message for the VLT to start operating again. A warning on the other hand may come when a warning condition appears, and disappear when conditions return to normal without interfering with the process.

■ Warnings

Any warning within the VLT is represented by a single bit within a warning word. A warning word is always an action parameter. Bit status FALSE [0] means no warning, while bit status TRUE [1] means warning. To each bit and each bit status there is a corresponding text string. In addition to the warning word message the master will also be notified through a change of bit 7 in the Status Word.

■ Alarms

Following an Alarm message the VLT will enter Fault condition. Only after the fault has been alleviated and the master has acknowledged the alarm message by setting bit 3 in the Control Word, can the VLT resume operation. Any warning within the VLT is represented by a single bit within a warning word. A warning word is always an action parameter. Bit status FALSE [0] means no fault, while bit status TRUE [1] means fault. To each bit and each bit status there is a corresponding text string.

■ Abbreviations

English	Elaboration
CAN	Controller Area Network
CTW	Control Word
COS	Change of State
EDS	Electronic Data Sheet
EMC	Electromagnetic Compatibility
FIFO	First In First Out
HPFB	High Performance Field Bus
IND	Subindex
I/O	Input/Output
ISO	International Standards Organization
LED	Light Emitting Diode
LSB	Least Significant Bit
MSB	Most Significant Bit
MAV	Main Actual Value
MRV	Main Reference Value
OD	Object Directory
IW	Peripheral input word
QW	Peripheral output word
PC	Personal Computer
PCD	Process Data
PCP	Peripherals Communication Protocol
PDU	Protocol Data Unit
PLC	Programmable Logic Control
STW	Status Word
VDE	Association of German Electrical Technicians
VDI	Association of German Electrical Engineers
VSD	Variable Speed Drive

■ Factory settings - VLT 2800

PNU #	Parameter description	Factory setting	4-setup	Conv. index	Data type
001	Language	English	No	0	5
002	Local/remote operation	Remote-controlled	Yes	0	5
003	Local reference	000,000.000	Yes	-3	4
004	Active Setup	Setup 1	No	0	5
005	Programming Setup	Active Setup	No	0	5
006	Setup copying	No copying	No	0	5
007	LCP copy	No copying	No	0	5
008	Display scaling	1.00	Yes	-2	6
009	Large display readout	Frequency [Hz]	Yes	0	5
010	Small display line 1.1	Reference [%]	Yes	0	5
011	Small display line 1.2	Motor current [A]	Yes	0	5
012	Small display line 1.3	Power [kW]	Yes	0	5
013	Local control	Remote control as par. 100	Yes	0	5
014	Local stop/reset	Active	Yes	0	5
015	Local jog	Not active	Yes	0	5
016	Local reversing	Not active	Yes	0	5
017	Local reset of trip	Active	Yes	0	5
018	Data change lock	Not locked	Yes	0	5
019	Operating status at power up	Forced stop, use saved ref.	Yes	0	5
020	Lock for Hand mode	Active	No	0	5
024	User-defined Quick Menu	Not active	No	0	5
025	Quick Menu Setup	000	No	0	6

4-Setup:

'Yes' means that the parameter can be programmed individually in each of the four Setups, i.e. one single parameter can have four different data values. 'No' means that the data value will be the same in all Setups.

Conversion index:

This number refers to a conversion figure to be used when writing or reading via serial communication with a frequency converter.

See *Data character* in *Serial communication*.

Data type:

Data type shows the type and length of the telegram.

Data type	Description
3	Integer 16
4	Integer 32
5	Unsigned 8
6	Unsigned 16
7	Unsigned 32
9	Text string ¹⁾

1. Not accessible from DeviceNet.

■ Factory settings - VLT 2800

PNU #	Parameter description	Factory setting	4-setup	Conv. index	Data type
100	Configuration	Speed reg., open loop	Yes	0	5
101	Torque characteristics	Constant torque	Yes	0	5
102	Motor power $P_{M,N}$	depends on unit	Yes	1	6
103	Motor voltage $U_{M,N}$	depends on unit	Yes	0	6
104	Motor frequency $f_{M,N}$	50 Hz	Yes	-1	6
105	Motor current $I_{M,N}$	depends on motor selected	Yes	-2	7
106	Rated motor speed	depends on par. 102	Yes	0	6
107	Automatic motor adjustment	Optimisation off	Yes	0	5
108	Stator resistance R_S	depends on motor selected	Yes	-3	7
109	Stator reactance X_S	depends on motor selected	Yes	-2	7
119	High start torque	0.0 sec	Yes	-1	5
120	Start delay	0.0 sec	Yes	-1	5
121	Start function	Coast in start del.	Yes	0	5
122	Function at stop	Coast	Yes	0	5
123	Min. freq. for activation of par. 122	0.1 Hz	Yes	-1	5
126	DC braking time	10 sec.	Yes	-1	6
127	DC brake engaging frequency	OFF	Yes	-2	6
128	Thermal motor protection	No protection	Yes	0	5
130	Start frequency	0.0 Hz	Yes	-1	5
131	Voltage at start	0.0 V	Yes	-1	6
132	DC brake voltage	0%	Yes	0	5
133	Start voltage	depends on unit	Yes	-2	6
134	Load compensation	100 %	Yes	-1	6
135	U/f-ratio	depends on unit	Yes	-2	6
136	Slip compensation	100 %	Yes	-1	3
137	DC hold voltage	0 %	Yes	0	5
138	Brake cut out value	3.0 Hz	Yes	-1	6
139	Brake cut in frequency	3.0 Hz	Yes	-1	6
140	Current, minimum value	0 %	Yes	0	5
142	Leak reactance	depends on motor selected	Yes	-3	7
143	Internal ventilator control	Automatic	Yes	0	5
144	AC brake factor	1.30	Yes	-2	5
146	Reset voltage vector	Off	Yes	0	5

■ Factory settings - VLT 2800

PNU #	Parameter description	Factory setting	4-setup	Conv. index	Data type
200	Output frequency range	Clockwise only, 0-132 Hz	Yes	0	5
201	Output frequency, low limit f_{MIN}	0.0 Hz	Yes	-1	6
202	Output frequency, high limit f_{MAX}	132 Hz	Yes	-1	6
203	Reference range	Min ref.-Max ref.	Yes	0	5
204	Minimum ref Ref_{MIN}	0.000 Hz	Yes	-3	4
205	Maximum ref Ref_{MAX}	50.000 Hz	Yes	-3	4
206	Ramp type	Linear	Yes	0	5
207	Ramp-up time 1	3.00 sec.	Yes	-2	7
208	Ramp-down time 1	3.00 sec.	Yes	-2	7
209	Ramp-up time 2	3.00 sec.	Yes	-2	7
210	Ramp-down time 2	3.00 sec.	Yes	-2	7
211	Jog ramp time	3.00 sec.	Yes	-2	7
212	Quick stop ramp-down time	3.00 sec.	Yes	-2	7
213	Jog frequency	10.0 Hz	Yes	-1	6
214	Reference function	Sum	Yes	0	5
215	Preset reference 1	0.00%	Yes	-2	3
216	Preset reference 2	0.00%	Yes	-2	3
217	Preset reference 3	0.00%	Yes	-2	3
218	Preset reference 4	0.00%	Yes	-2	3
219	Catch up/slow down reference	0.00%	Yes	-2	6
221	Current limit	160 %	Yes	-1	6
223	Warn. Low current	0.0 A	Yes	-1	6
224	Warn. High current	I_{MAX}	Yes	-1	6
225	Warn. Low frequency	0.0 Hz	Yes	-1	6
226	Warn. High frequency	132.0 Hz	Yes	-1	6
227	Warn. Low Feedback	-4000.000	Yes	-3	4
228	Warn.High Feedback	4000.000	Yes	-3	4
229	Frequency bypass, bandwidth	0 Hz (OFF)	Yes	0	6
230	Frequency bypass 1	0.0 Hz	Yes	-1	6
231	Frequency bypass 2	0.0 Hz	Yes	-1	6

■ Factory settings - VLT 2800

PNU #	Parameter description	Factory setting	4-setup	Conv. index	Data type
302	Digital input, term. 18	Start	Yes	0	5
303	Digital input, term. 19	Reversing	Yes	0	5
304	Digital input, term. 27	Reset and coast inverse	Yes	0	5
305	Digital input, term. 29	Jog	Yes	0	5
307	Digital input, term. 33	No function	Yes	0	5
308	Term. 53, analogue input voltage	Reference	Yes	0	5
309	Term. 53, min scaling	0.0 V	Yes	-1	6
310	Term. 53, max scaling	10.0 V	Yes	-1	6
314	Term. 60, analogue input current	No function	Yes	0	5
315	Term. 60, min scaling	0.0 mA	Yes	-4	6
316	Term. 60, max scaling	20.0 mA	Yes	-4	6
317	Time out	10 sec.	Yes	0	5
318	Function after timeout	No function	Yes	0	5
319	Term. 42, analogue output	0-I _{MAX} = 0-20 mA	Yes	0	5
323	Relay output	Control ready	Yes	0	5
327	Pulse ref./FB	5000 Hz	Yes	0	7
341	Term. 46 digital output	Control ready	Yes	0	5
342	Term. 46 Max. pulse output	5000 Hz	Yes	0	6
343	Precise stop function	Normal ramp stop	Yes	0	5
344	Counter value	100000 pulses	Yes	0	7
349	Speed comp delay	10 ms	Yes	-3	6

4-Setup:

'Yes' means that the parameter can be programmed individually in each of the four Setups, i.e. one single parameter can have four different data values. 'No' means that the data value will be the same in all Setups.

Conversion index:

This number refers to a conversion figure to be used when writing or reading via serial communication with a frequency converter.

See *Data character* in *Serial communication*.

Data type:

Data type shows the type and length of the telegram.

Data type	Description
3	Integer 16
4	Integer 32
5	Unsigned 8
6	Unsigned 16
7	Unsigned 32
9	Text string ¹⁾

1. Not accessible from DeviceNet.

■ Factory settings - VLT 2800

PNU #	Parameter description	Factory setting	4-setup	Conv. index	Data type
400	Brake function	Depends on unit type	No	0	5
405	Reset function	Manual reset	Yes	0	5
406	Aut. restart time	5 sec.	Yes	0	5
409	Trip delay overcurrent	Off (61 sec.)	Yes	0	5
411	Switching frequency	4.5 kHz	Yes	0	6
412	Var. carrier frequency	No LC-filter	Yes	0	5
413	Overmodulation function	On	Yes	0	5
414	Min. feedback	0.000	Yes	-3	4
415	Max. feedback	1500.000	Yes	-3	4
416	Process units	No unit	Yes	0	5
417	Speed PID propor.ampl.	0.010	Yes	-3	6
418	Speed PID intergra.	100 ms	Yes	-5	7
419	Speed PID differentiation time	20.00 ms	Yes	-5	7
420	Speed PID diff. amplification limit	5.0	Yes	-1	6
421	Speed PID lowpass filter	20 ms	Yes	-3	6
423	U1 voltage	par. 103	Yes	-1	6
424	F1 frequency	Par. 104	Yes	-1	6
425	U2 voltage	par. 103	Yes	-1	6
426	F2 frequency	par. 104	Yes	-1	6
427	U3 voltage	par. 103	Yes	-1	6
428	F3 frequency	par. 104	Yes	-1	6
437	Proc. PID no/inv.	Normal	Yes	0	5
438	Proc. PID anti wind.	Active	Yes	0	5
439	Proc. PID start frequency	Par. 201	Yes	-1	6
440	Proc. PID start proportional ampl.	0.01	Yes	-2	6
441	Proc. PID integration time	Off (9999.99 s)	Yes	-2	7
442	Proc. PID differentiation time	Off (0.00 s).	Yes	-2	6
443	Proc. PID diff. ampl. limit	5.0	Yes	-1	6
444	Proc. PID lowpass filter time	0.02 s	Yes	-2	6
445	Flying start	Not possible	Yes	0	5
451	Speed PID feedforward factor	100%	Yes	0	6
452	Controller range	10 %	Yes	-1	6
456	Brake voltage reduce	0	Yes	0	5

■ Factory settings - VLT 2800

PNU #	Parameter description	Factory setting	4-setup	Conv. index	Data type
500	Address	1	No	0	5
501	Baudrate	9600 Baud	No	0	5
502	Coasting stop	Logic or	Yes	0	5
503	Quick stop	Logic or	Yes	0	5
504	DC brake	Logic or	Yes	0	5
505	Start	Logic or	Yes	0	5
506	Reversing	Logic or	Yes	0	5
507	Selection of Setup	Logic or	Yes	0	5
508	Selection of preset ref.	Logic or	Yes	0	5
509	Bus jog 1	10.0 Hz	Yes	-1	6
510	Bus jog 2	10.0 Hz	Yes	-1	6
512	Telegram profile	FC protocol	Yes	0	5
513	Bus time interval	1 sec.	Yes	0	5
514	Bus time interval function	Off	Yes	0	5
515	Data readout: Reference %		No	-1	3
516	Data readout: Reference [unit]		No	-3	4
517	Data readout: Feedback [unit]		No	-3	4
518	Data readout: Frequency		No	-1	3
519	Data readout: Frequency x scaling		No	-1	3
520	Data readout: Motor current		No	-2	7
521	Data readout: Torque		No	-1	3
522	Data readout: Power [kW]		No	1	7
523	Data readout: Power [HP]		No	-2	7
524	Data readout: Motor voltage [V]		No	-1	6
525	Data readout: DC Link voltage		No	0	6
526	Data readout: Motor thermal load		No	0	5
527	Data readout: Inverter thermal load		No	0	5
528	Data readout: Digital input		No	0	5
529	Data readout: Analogue input, term. 53		No	-1	5
531	Data readout: Analogue input, term. 60		No	-4	5
532	Data readout: Pulse reference		No	-1	7
533	Data readout: External reference		No	-1	6
534	Data readout: Status word		No	0	6
537	Data readout: Inverter temperature		No	0	5
538	Data readout: Alarm word		No	0	7
539	Data readout: Control word		No	0	6
540	Data readout: Warning word		No	0	7
541	Data readout: Extended status word		No	0	7
544	Data readout: Pulse count		No	0	7

■ Factory settings - VLT 2800

PNU #	Parameter description	Factory setting	4-setup	Conv. index	Data type
600	Operating hours		No	73	7
601	Hours run		No	73	7
602	kWh counter		No	2	7
603	Number of cut ins		No	0	6
604	Number of overtemperatures		No	0	6
605	Number of overvoltages		No	0	6
615	Fault log: Error code		No	0	5
616	Fault log: Time		No	0	7
617	Fault log: Value		No	0	3
618	Reset of kWh counter	No reset	No	0	7
619	Reset of running hours counter	No reset	No	0	5
620	Operation mode	Normal operation	No	0	5
621	Nameplate: Unit type		No	0	9
624	Nameplate: Software version		No	0	9
625	Nameplate: LCP identification no.		No	0	9
626	Nameplate: Database identification no.		No	-2	9
627	Nameplate: Power parts version		No	0	9
628	Nameplate: Application option type		No	0	9
630	Nameplate: Communication option type		No	0	9
632	Nameplate: BMC software identification		No	0	9
633	Nameplate: Motor database identification		No	0	9
634	Nameplate: Unit identification for communication		No	0	9
635	Nameplate: Software parts no.		No	0	9
640	Software version		No	-2	6
641	BMC software identification		No	-2	6
642	Power card identification		No	-2	6

4-Setup:

'Yes' means that the parameter can be programmed individually in each of the four Setups, i.e. one single parameter can have four different data values. 'No' means that the data value will be the same in all Setups.

Conversion index:

This number refers to a conversion figure to be used when writing or reading via serial communication with a frequency converter.

See *Data character* in *Serial communication*.

Data type:

Data type shows the type and length of the telegram.

Data type	Description
3	Integer 16
4	Integer 32
5	Unsigned 8
6	Unsigned 16
7	Unsigned 32
9	Text string ¹⁾

1. Not accessible from DeviceNet.

■ Factory settings - VLT 2800

PNU #	Parameter description	Factory setting	Changes during operation	4-Setup	Conversion-index	Data Type
801	Baud rate selection	125 kbps	Yes	No	0	5
803	Time after bus error	1 sec.	Yes	No	0	5
804	Response after bus error	Off	Yes	No	0	5
805	Function control word bit Bit 10	Bit 10 = CTW active	Yes	No	0	5
832	Bus Off Interrupt Behavior	Hold Can	Yes	No	0	5
833	Fieldbus Enable 0	Disable	No	No	0	5
834	Filter Mask 1	FFFFh	Yes	No	0	6
835	Filter Mask 2	FFFFh	Yes	No	0	6
836	Filter Mask 3	FFFFh	Yes	No	0	6
837	Filter Mask 4	FFFFh	Yes	No	0	6
838	ESD Data type	Errata 2	No	No	0	5
850	Readout Transmit Error Counter	0	No	No	0	5
851	Readout Receive Error Counter	0	No	No	0	5
852	Readout Bus Off Counter	0	No	No	0	5
860	Controlword	0	Yes	No	0	Bit sequence
861	Reference Value	0	No	No	0	Signed 16
880	Statusword	0	No	No	0	Bit sequence
881	Main Actual Value	0	No	No	0	Signed 16
904	PPO selection	10	Yes	No	0	6
915	PCD write configuration	0	Yes	No	0	6
916	PCD read configuration	0	Yes	No	0	6
917	Active Spontaneous Message	OFF	Yes	No	0	Bit sequence
918	Station Address	63	Yes	No	0	6
953	Warning Messages	0	No	No	0	Bit sequence
967	Control Word	0	Yes	No	0	Bit sequence
968	Status Word	0	No	No	0	Bit sequence
970	Parameter setup selection	Active setup	Yes	No	0	5
971	Save data values	No action	Yes	No	0	5
980	1 Defined parameters	0	No	No	0	6
981	2 Defined parameters	0	No	No	0	6
982	3 Defined parameters	0	No	No	0	6
990	1 Modified parameters	0	No	No	0	6
991	2 Modified parameters	0	No	No	0	6
992	3 Modified parameters	0	No	No	0	6

** Automatic reset to (0)

S Only in stop mode (VLT must be stopped in order to change data value)

■ Factory settings - FCD 300

PNU #	Parameter description	Factory setting	4-setup	Conv. index	Data type
001	Language	English	No	0	5
002	Local/remote operation	Remote-controlled	Yes	0	5
003	Local reference	000,000.000	Yes	-3	4
004	Active Setup	Setup 1	No	0	5
005	Programming Setup	Active Setup	No	0	5
006	Setup copying	No copying	No	0	5
007	LCP copy	No copying	No	0	5
008	Display scaling	1.00	Yes	-2	6
009	Large display readout	Frequency [Hz]	Yes	0	5
010	Small display line 1.1	Reference [%]	Yes	0	5
011	Small display line 1.2	Motor current [A]	Yes	0	5
012	Small display line 1.3	Power [kW]	Yes	0	5
013	Local control	Remote control as par. 100	Yes	0	5
014	Local stop/reset	Active	Yes	0	5
015	Local jog	Not active	Yes	0	5
016	Local reversing	Not active	Yes	0	5
017	Local reset of trip	Active	Yes	0	5
018	Data change lock	Not locked	Yes	0	5
019	Operating status at power up	Forced stop, use saved ref.	Yes	0	5
024	User-defined Quick Menu	Not active	No	0	5
025	Quick Menu Setup	000	No	0	6
026	LED Status	Overload	Yes	0	5

4-Setup:

'Yes' means that the parameter can be programmed individually in each of the four Setups, i.e. one single parameter can have four different data values. 'No' means that the data value will be the same in all Setups.

Conversion index:

This number refers to a conversion figure to be used when writing or reading via serial communication with a frequency converter.

See *Data character* in *Serial communication*.

Data type:

Data type shows the type and length of the telegram.

Data type	Description
3	Integer 16
4	Integer 32
5	Unsigned 8
6	Unsigned 16
7	Unsigned 32
9	Text string

■ Factory settings - FCD 300

PNU #	Parameter-description	Factory setting	4-setup	Conv. index	Data-type
100	Configuration	Speed reg., open loop	Yes	0	5
101	Torque characteristics	Constant torque	Yes	0	5
102	Motor power $P_{M,N}$	depends on unit	Yes	1	6
103	Motor voltage $U_{M,N}$	depends on unit	Yes	0	6
104	Motor frequency $f_{M,N}$	50 Hz	Yes	-1	6
105	Motor current $I_{M,N}$	depends on motor selected	Yes	-2	7
106	Rated motor speed	depends on par. 102	Yes	0	6
107	Automatic motor adjustment	Optimisation off	Yes	0	5
108	Stator resistance R_S	depends on motor selected	Yes	-3	7
109	Stator reactance X_S	depends on motor selected	Yes	-2	7
117	Resonance dampening	0 %	Yes	0	5
119	High start torque	0.0 sec	Yes	-1	5
120	Start delay	0.0 sec	Yes	-1	5
121	Start function	Coast in start del.	Yes	0	5
122	Function at stop	Coast	Yes	0	5
123	Min. freq. for activation of par. 122	0.1 Hz	Yes	-1	5
126	DC braking time	10 sec.	Yes	-1	6
127	DC brake engaging frequency	OFF	Yes	-2	6
128	Thermal motor protection	No protection	Yes	0	5
130	Start frequency	0.0 Hz	Yes	-1	5
131	Voltage at start	0.0 V	Yes	-1	6
132	DC brake voltage	0%	Yes	0	5
133	Start voltage	depends on unit	Yes	-2	6
134	Load compensation	100 %	Yes	-1	6
135	U/f-ratio	depends on unit	Yes	-2	6
136	Slip compensation	100 %	Yes	-1	3
137	DC hold voltage	0%	Yes	0	5
138	Brake cut out value	3.0 Hz	Yes	-1	6
139	Brake cut in frequency	3.0 Hz	Yes	-1	6
140	Current, minimum value	0%	Yes	0	5
142	Leak reactance	depends on motor selected	Yes	-3	7
144	AC brake factor	1.30	Yes	-2	5
146	Reset voltage vector	Off	Yes	0	5

■ Factory settings - FCD 300

PNU #	Parameter description	Factory setting	4-setup	Conv. index	Data type
200	Output frequency range	Clockwise only, 0-132 Hz	Yes	0	5
201	Output frequency, low limit f_{MIN}	0.0 Hz	Yes	-1	6
202	Output frequency, high limit f_{MAX}	132 Hz	Yes	-1	6
203	Reference range	Min ref.-Max ref.	Yes	0	5
204	Minimum ref Ref_{MIN}	0.000 Hz	Yes	-3	4
205	Maximum ref Ref_{MAX}	50.000 Hz	Yes	-3	4
206	Ramp type	Linear	Yes	0	5
207	Ramp-up time 1	3.00 sec.	Yes	-2	7
208	Ramp-down time 1	3.00 sec.	Yes	-2	7
209	Ramp-up time 2	3.00 sec.	Yes	-2	7
210	Ramp-down time 2	3.00 sec.	Yes	-2	7
211	Jog ramp time	3.00 sec.	Yes	-2	7
212	Quick stop ramp-down time	3.00 sec.	Yes	-2	7
213	Jog frequency	10.0 Hz	Yes	-1	6
214	Reference function	Sum	Yes	0	5
215	Preset reference 1	0.00%	Yes	-2	3
216	Preset reference 2	0.00%	Yes	-2	3
217	Preset reference 3	0.00%	Yes	-2	3
218	Preset reference 4	0.00%	Yes	-2	3
219	Catch up/slow down reference	0.00%	Yes	-2	6
221	Current limit	160 %	Yes	-1	6
223	Warn. Low current	0.0 A	Yes	-1	6
224	Warn. High current	I_{MAX}	Yes	-1	6
225	Warn. Low frequency	0.0 Hz	Yes	-1	6
226	Warn. High frequency	132.0 Hz	Yes	-1	6
227	Warn. Low Feedback	-4000.000	Yes	-3	4
228	Warn.High Feedback	4000.000	Yes	-3	4
229	Frequency bypass, bandwidth	0 Hz (OFF)	Yes	0	6
230	Frequency bypass 1	0.0 Hz	Yes	-1	6
231	Frequency bypass 2	0.0 Hz	Yes	-1	6

■ Factory settings - FCD 300

PNU #	Parameter description	Factory setting	4-setup	Conv. index	Data type
302	Digital input, term. 18	Start	Yes	0	5
303	Digital input, term. 19	Reversing	Yes	0	5
304	Digital input, term. 27	Reset and coast inverse	Yes	0	5
305	Digital input, term. 29	Jog	Yes	0	5
307	Digital input, term. 33	No function	Yes	0	5
308	Term. 53, analogue input voltage	Reference	Yes	0	5
309	Term. 53, min scaling	0.0 V	Yes	-1	6
310	Term. 53, max scaling	10.0 V	Yes	-1	6
314	Term. 60, analogue input current	No function	Yes	0	5
315	Term. 60, min scaling	0.0 mA	Yes	-4	6
316	Term. 60, max scaling	20.0 mA	Yes	-4	6
317	Time out	10 sec.	Yes	0	5
318	Function after timeout	No function	Yes	0	5
319	Term. 42, analogue output	0-I _{MAX} = 0-20 mA	Yes	0	5
323	Relay output	Control ready	Yes	0	5
327	Pulse Max. 33	5000 Hz	Yes	0	7
328	Pulse Max. 29	5000 Hz	Yes	0	7
341	Term. 46 digital output	Control ready	Yes	0	5
342	Term. 46 Max. pulse output	5000 Hz	Yes	0	6
343	Precise stop function	Normal ramp stop	Yes	0	5
344	Counter value	100000 pulses	Yes	0	7
349	Speed comp delay	10 ms	Yes	-3	6

4-Setup:

'Yes' means that the parameter can be programmed individually in each of the four Setups, i.e. one single parameter can have four different data values. 'No' means that the data value will be the same in all Setups.

Conversion index:

This number refers to a conversion figure to be used when writing or reading via serial communication with a frequency converter.

See *Data character* in *Serial communication*.

Data type:

Data type shows the type and length of the telegram.

Data type	Description
3	Integer 16
4	Integer 32
5	Unsigned 8
6	Unsigned 16
7	Unsigned 32
9	Text string

■ Factory settings - FCD 300

PNU #	Parameter description	Factory setting	4-setup	Conv. index	Data type
400	Brake function	Depends on unit type	No	0	5
405	Reset function	Manual reset	Yes	0	5
406	Aut. restart time	5 sec.	Yes	0	5
409	Trip delay overcurrent	Off (61 sec.)	Yes	0	5
411	Switching frequency	4.5 kHz	Yes	0	6
413	Overmodulation function	On	Yes	0	5
414	Min. feedback	0.000	Yes	-3	4
415	Max. feedback	1500.000	Yes	-3	4
416	Process units	No unit	Yes	0	5
417	Speed PID propor.ampl.	0.010	Yes	-3	6
418	Speed PID intergra.	100 ms	Yes	-5	7
419	Speed PID differentiation time	20.00 ms	Yes	-5	7
420	Speed PID diff. amplification limit	5.0	Yes	-1	6
421	Speed PID lowpass filter	20 ms	Yes	-3	6
423	U1 voltage	par. 103	Yes	-1	6
424	F1 frequency	Par. 104	Yes	-1	6
425	U2 voltage	par. 103	Yes	-1	6
426	F2 frequency	par. 104	Yes	-1	6
427	U3 voltage	par. 103	Yes	-1	6
428	F3 frequency	par. 104	Yes	-1	6
437	Proc. PID no/inv.	Normal	Yes	0	5
438	Proc. PID anti wind.	Active	Yes	0	5
439	Proc. PID start frequency	Par. 201	Yes	-1	6
440	Proc. PID start proportional ampl.	0.01	Yes	-2	6
441	Proc. PID integration time	Off (9999.99 s)	Yes	-2	7
442	Proc. PID differentiation time	Off (0.00 s).	Yes	-2	6
443	Proc. PID diff. ampl. limit	5.0	Yes	-1	6
444	Proc. PID lowpass filter time	0.02 s	Yes	-2	6
445	Flying start	Not possible	Yes	0	5
451	Speed PID feedforward factor	100%	Yes	0	6
452	Controller range	10 %	Yes	-1	6
456	Brake voltage reduce	0	Yes	0	5

■ Factory settings - FCD 300

PNU #	Parameter description	Factory setting	4-setup	Conv. in-dex	Data type
500	Address	1	No	0	5
501	Baudrate	9600 Baud	No	0	5
502	Coasting stop	Logic or	Yes	0	5
503	Quick stop	Logic or	Yes	0	5
504	DC brake	Logic or	Yes	0	5
505	Start	Logic or	Yes	0	5
506	Reversing	Logic or	Yes	0	5
507	Selection of Setup	Logic or	Yes	0	5
508	Selection of preset ref.	Logic or	Yes	0	5
509	Bus jog 1	10.0 Hz	Yes	-1	6
510	Bus jog 2	10.0 Hz	Yes	-1	6
512	Telegram profile	FC protocol	Yes	0	5
513	Bus time interval	1 sec.	Yes	0	5
514	Bus time interval function	Off	Yes	0	5
515	Data readout: Reference %		No	-1	3
516	Data readout: Reference [unit]		No	-3	4
517	Data readout: Feedback [unit]		No	-3	4
518	Data readout: Frequency		No	-1	3
519	Data readout: Frequency x scaling		No	-1	3
520	Data readout: Motor current		No	-2	7
521	Data readout: Torque		No	-1	3
522	Data readout: Power [kW]		No	1	7
523	Data readout: Power [HP]		No	-2	7
524	Data readout: Motor voltage [V]		No	-1	6
525	Data readout: DC Link voltage		No	0	6
526	Data readout: Motor thermal load		No	0	5
527	Data readout: Inverter thermal load		No	0	5
528	Data readout: Digital input		No	0	5
529	Data readout: Analogue input, term. 53		No	-1	5
531	Data readout: Analogue input, term. 60		No	-4	5
532	Data readout: Pulse input, term. 33		No	-1	7
533	Data readout: External reference		No	-1	6
534	Data readout: Status word		No	0	6
537	Data readout: Inverter temperature		No	0	5
538	Data readout: Alarm word		No	0	7
539	Data readout: Control word		No	0	6
540	Data readout: Warning word		No	0	7
541	Data readout: Extended status word		No	0	7
544	Data readout: Pulse count		No	0	7
545	Data readout: Pulse input, term. 29		No	-1	7

■ Factory settings - FCD 300

PNU #	Parameter description	Factory setting	4-setup	Conv. index	Data type
600	Operating hours		No	73	7
601	Hours run		No	73	7
602	kWh counter		No	2	7
603	Number of cut ins		No	0	6
604	Number of overtemperatures		No	0	6
605	Number of overvoltages		No	0	6
615	Fault log: Error code		No	0	5
616	Fault log: Time		No	0	7
617	Fault log: Value		No	0	3
618	Reset of kWh counter	No reset	No	0	7
619	Reset of running hours counter	No reset	No	0	5
620	Operation mode	Normal operation	No	0	5
621	Nameplate: Unit type		No	0	9
624	Nameplate: Software version		No	0	9
625	Nameplate: LCP identification no.		No	0	9
626	Nameplate: Database identification no.		No	-2	9
627	Nameplate: Power parts version		No	0	9
628	Nameplate: Application option type		No	0	9
630	Nameplate: Communication option type		No	0	9
632	Nameplate: BMC software identification		No	0	9
633	Nameplate: Motor database identification		No	0	9
634	Nameplate: Unit identification for communication		No	0	9
635	Nameplate: Software parts no.		No	0	9
640	Software version		No	-2	6
641	BMC software identification		No	-2	6
642	Power card identification		No	-2	6
678	Configure Control Card		No	0	5

4-Setup:

'Yes' means that the parameter can be programmed individually in each of the four Setups, i.e. one single parameter can have four different data values. 'No' means that the data value will be the same in all Setups.

Conversion index:

This number refers to a conversion figure to be used when writing or reading via serial communication with a frequency converter.

See *Data character* in *Serial communication*.

Data type:

Data type shows the type and length of the telegram.

Data type	Description
3	Integer 16
4	Integer 32
5	Unsigned 8
6	Unsigned 16
7	Unsigned 32
9	Text string

■ Additional control features for VLT 2800

VLT 2800 Additional control features

Three new means of controlling are available with the DeviceNet version of the VLT 2800:

Reference and feedback as pulse inputs, A/B pulse encoder signals and ± 10 Volt analogue input (53).

Terminals 29 and 33 can be configured as either pulse reference or pulse feedback. The maximum pulse

frequencies are set in par. 327 and 328 respectively. A 24 V encoder with dual track (A-B) pulse train with direction recognition (quadrature signals) can be connected to terminals 29 and 33. Track A must be connected to terminal 29 and track B to 33.

The encoder can be used for either reference, feedback, or as input for the counter function.

Digital inputs	Term. no.	29	33
	par. no.	305	307
Value:			
Pulse reference	(PULSE REFERENCE)	[28]	[28]
Pulse feedback	(PULSE FEEDBACK)	[29]	[29]
Pulse input	(PULSE INPUT)	[30]	[30]
Encoder reference	(ENCODER REFERENCE)	[40] ¹	[40] ¹
Encoder feedback	(ENCODER FEEDBACK)	[41] ¹	[41] ¹
Encoder input	(ENCODER INPUT)	[42] ¹	[42] ¹

1. Settings must be identical for terminal 29 and 33.

Encoder reference is selected if the reference signal applied is an A-B encoder signal. 0 Hz corresponds to the setting in par. 204 minimum reference. For running in both directions par. 203 should be set to -max - +max [1], par. 200 to both directions [1], and par. 204 minimum reference to 0.00. The frequency set in par. 327/328 pulse max. 33/29 (will be equaled automatically) corresponds to the value in par. 205 maximum reference.

Encoder feedback is selected if the feedback signal applied is an A-B encoder signal. The frequency set in par. 327/328 pulse max. 33/29 (will be equaled automatically) corresponds to the value in par. 205 maximum feedback.

Encoder input is selected if the encoder signals are to be used for the counter function with precise stop selectable in par. 343 precise stop. The number of pulse before ramp down is specified in par. 344 counter value.

Example, 0 - ± 10 Volt:

External reference signal = 0 V (min) ± 10 V (max)
 Reference = 50 Hz ccw - 50 Hz cw
 Configuration (parameter 100) = Speed control, open loop

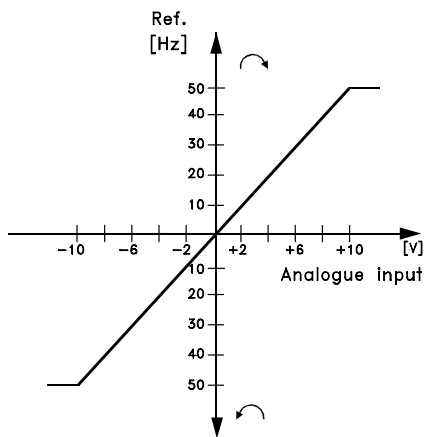

195NA242.10

Setting:			
Parameter:		Setting:	Data value:
100	Configuration	Speed control, open loop	[0]
308	Funct. of analogue input	Reference	[1]
309	Min. reference signal	Min.	0 V
310	Max. reference signal	Max.	10 V
203	Reference range	Reference range	- Max - + Max [1]
205	Max. reference		50 Hz
200	Output frequency range/direction	Both directions, 0-132 Hz	[1]