

Contents

Safety note	4
Introduction	5
About this Manual	5
Technical Overview	5
Assumptions	6
Hardware.....	6
Background Knowledge.....	6
FC 300-related Literature	6
Abbreviations	6
How to Install	9
Cabling.....	9
Cable Lengths.....	9
Cable Specifications.....	9
EMC Precautions	10
Connection of the Cable Screen.....	11
Earth Connection	11
CANopen Connection	12
CANopen Termination	12
Installation of Option in Drive	13
How to Configure the System	14
Set the CANopen Address.....	14
Set the CANopen Address via Parameter 10-02 <i>Drive Node ID</i> :	14
Set the CANopen Baud Rate	14
Set the CANopen Baud Rate via Parameter 10-01 <i>Baudrate select</i> :.....	14
Configure the Network	15
Network Management NMT	15
1005h, 1006h, 1007h Synchronization Object (SYNC)	15
1017h Producer Heartbeat Time	15
1014h, 1015h Emergency object (EMCY)	16
Configure the FC 300.....	17
VLT Parameters	17
LEDs.....	17
How to Control the FC300	18
Device Profile	18
Communication in CANopen.....	18
Communication Profile Area (1000h-1FFFh)	20
Communication object overview	20
1000h Device type.....	21
1001h Error register	21
1002h Manufacturer status register.....	21
1003h Predefined error field.....	21
1005h COB-ID Sync Message object.....	22
1008h Manufacturer Device Name.....	22
1009h Manufacturer Hardware Version	22
100Ah Manufacturer Software Version	22
100Ch Guard time	22
100Dh Life time factor.....	22
1010h Store parameters.....	22
1011h Restore default parameters	23
1014h COB ID emergency object	23
1018h Identity object.....	23
DSP 402 Control Profile.....	24
Control Word according to DSP 402 profile. (Par. 8-10 = DSP 402 profile)	24
Status Word according to DSP 402 profile. (Par. 8-10 = DSP 402 profile)	25
Standardised Device Profile Area	27
Danfoss FC control profile.....	28
Bus Speed Reference Value.....	31

Process Data Objects (PDO)	32
Structure of PDO COB-ID entry	32
PDO Usage	32
PDO Transmission Modes	33
PDO Triggering Modes	33
PDO Services	33
Receive PDO	34
1 st receive PDO (M): Control Word	34
6 th receive PDO: Target Velocity	35
21 st receive PDO: PCD 0 and PCD 1	35
22 nd receive PDO: PCD 2, PCD 3, PCD 4, PCD 5	35
Transmit PDO	36
1 st transmit PDO	36
6 th transmit PDO	36
21 st transmit PDO.....	37
22 nd transmit PDO.....	37
Danfoss Specific Objects (2000h-5FFFh).....	38
How to Access FC 300 Parameters	39
Service Data Objects (SDO).....	39
Initiate download.....	40
Download segment	41
Initiate upload	41
Upload segment	42
Example: Initiate Upload (read data).....	43
SDO Abort Code	44
Parameters	45
Parameter List.....	50
Data Types Supported by FC 300	51
Object and Data Types Supported by FC 300	51
Conversion index.....	51
Application Examples	Error! Bookmark not defined.
Example: SDO Communication.....	Error! Bookmark not defined.
Example: PDO Communication.....	Error! Bookmark not defined.
Troubleshooting	52
Troubleshooting.....	52
LED Status	52
Module Status (MS) LED, red	53
Network Status (NS) LED, green	53
Other states	53
No Communication with the Drive	54
Drive Will Not Respond to Control Signals	55
Alarm Word and Warning Word.....	59
Alarm / Warning Limits.....	60
Index	61

This publication contains information proprietary to Danfoss A/S. By accepting and using this manual the user agrees that the information contained herein will be used solely for operating equipment from Danfoss A/S or equipment from other vendors provided that such equipment is intended for communication with Danfoss equipment over a CANopen serial communication link. This publication is protected under the Copyright laws of Denmark and most other countries.

Danfoss A/S does not warrant that a software program produced according to the guidelines provided in this manual will function properly in every physical, hardware or software environment.

Although Danfoss A/S has tested and reviewed the documentation within this manual, Danfoss A/S makes no warranty or representation, either express or implied, with respect to this documentation, including its quality, performance, or fitness for a particular purpose.

In no event shall Danfoss A/S be liable for direct, indirect, special, incidental, or consequential damages arising out of the use, or the inability to use information contained in this manual, even if advised of the possibility of such damages. In particular, Danfoss A/S is not responsible for any costs including but not limited to those incurred as a result of lost profits or revenue, loss or damage of equipment, loss of computer programs, loss of data, the costs to substitute these, or any claims by third parties.

Danfoss A/S reserves the right to revise this publication at any time and to make changes in its contents without prior notice or any obligation to notify previous users of such revisions or changes.

Safety note



The voltage of the frequency converter is dangerous whenever connected to mains. Incorrect installation of the motor, frequency converter or fieldbus may cause damage to the equipment, serious personal injury or death. Consequently, the instructions in this manual, as well as national and local rules and safety regulations, must be complied with.

Safety Regulations

1. The frequency converter must be disconnected from mains if repair work is to be carried out. Check that the mains supply has been disconnected and that the necessary time has passed before removing motor and mains plugs.
2. The [STOP/RESET] key on the control panel of the frequency converter does not disconnect the equipment from mains and is thus not to be used as a safety switch.
3. Correct protective earthing of the equipment must be established, the user must be protected against supply voltage, and the motor must be protected against overload in accordance with applicable national and local regulations.
3. Correct protective earthing of the equipment must be established, the user must be protected against supply voltage, and the motor must be protected against overload in accordance with applicable national and local regulations.
4. The earth leakage currents are higher than 3.5 mA.
5. Protection against motor overload is not included in the factory setting. If this function is desired, set par. 1-90 *Motor Thermal Protection* to data value *ETR trip* or data value *ETR warning*. Note: The function is initialised at 1.16 x rated motor current and rated motor frequency. For the North American market: The ETR functions provide class 20 motor overload protection in accordance with NEC.
6. Do not remove the plugs for the motor and mains supply while the frequency converter is connected to mains. Check that the mains supply has been disconnected and that the necessary time has passed before removing motor and mains plugs.
7. Please note that the frequency converter has more voltage inputs than L1, L2 and L3, when load sharing (linking of DC intermediate circuit) and external 24 V DC have been installed. Check that all voltage inputs have been disconnected and that the necessary time has passed before commencing repair work.

Warning against Unintended Start

1. The motor can be brought to a stop by means of digital commands, bus commands, references or a local stop, while the frequency converter is connected to mains. If personal safety considerations make it necessary to ensure that no unintended start occurs, these stop functions are not sufficient.
2. While parameters are being changed, the motor may start. Consequently, the stop key [STOP/RESET] must always be activated; following which data can be modified.
3. A motor that has been stopped may start if faults occur in the electronics of the frequency converter, or if a temporary overload or a fault in the supply mains or the motor connection ceases.



Warning:

Touching the electrical parts may be fatal - even after the equipment has been disconnected from mains.

Also make sure that other voltage inputs have been disconnected, such as external 24 V DC, load sharing (linkage of DC intermediate circuit), as well as the motor connection for kinetic back up. Please refer to FC 300 Operating Instructions (MG.33.A1.02) for further safety guidelines.

Introduction

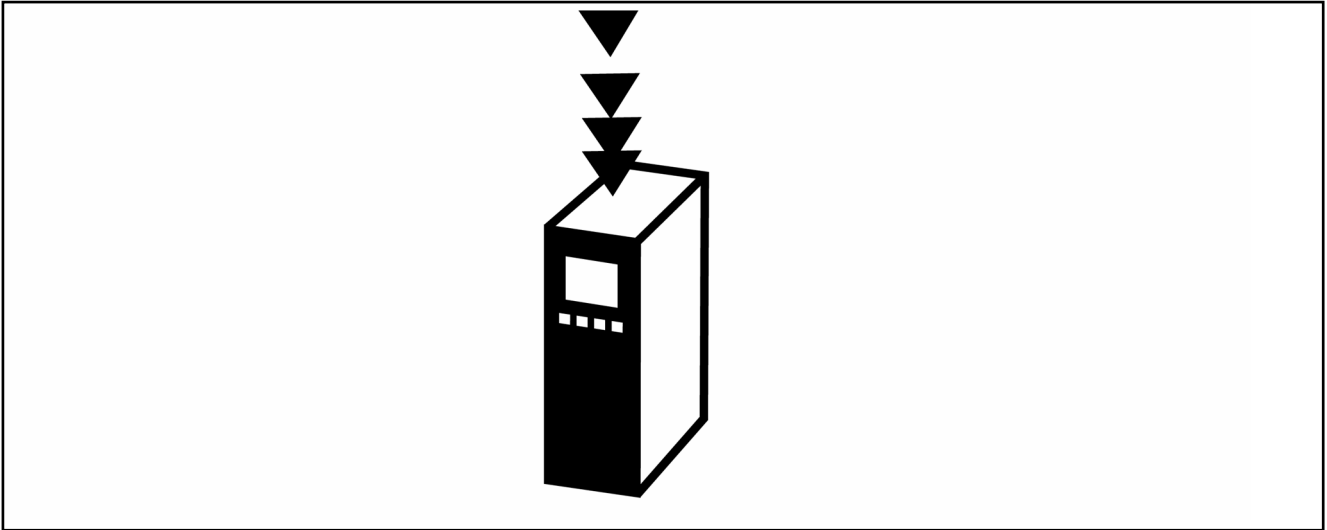

About this Manual

First time users can obtain the most essential information for quick installation and set-up in these chapters:

Introduction
How to Install
How to Configure the System
Application Examples

For more detailed information including the full range of set-up options and diagnosis tools please refer to the chapters:

How to Control the FC 300
How to Access FC 300 Parameters
Parameters
Troubleshooting

Technical Overview

CANopen is a low-level network that standardizes communications between industrial devices (sensors, limit switches, motor controls) and high-level devices (controllers). CANopen follows the Open Systems Interconnection (OSI) model and is based on CAN technology for Media Access Control and Physical Signalling.

CANopen is designed on the basis of three standards: DS102 *CAN Physical Layer for Industrial Applications*, DS 301 *CANopen Communication Profile for Industrial Systems* and DSP 402 *Device Profile Drives and Motion Control*.

CANopen systems can be configured to operate in a master-slave or a distributed control architecture using peer-to-peer communication. Up to 127 nodes in a multi-drop network topology are supported, and communication options can be powered directly from the bus, using the same cable for communication. Nodes can be removed or inserted without powering down the network.

Each node on the network has its own unique Communication Object Identifier (COB-ID) to distinguish it on the network. The access control is based on the CSMA/CA (Carrier Sense Multiple Access / Collision Avoidance) principle, meaning that all nodes may have access to the network at the same time. If two nodes attempt to get control of the network bus simultaneously, the CAN protocol resolves the issue by arbitration. In this way collisions on the network are avoided.

CANopen defines device profiles for devices belonging to specific classes. For other devices, a custom class must be defined in order to make it CANopen compatible. This further enhances the interchangeability and interoperability of the network.

- Introduction -

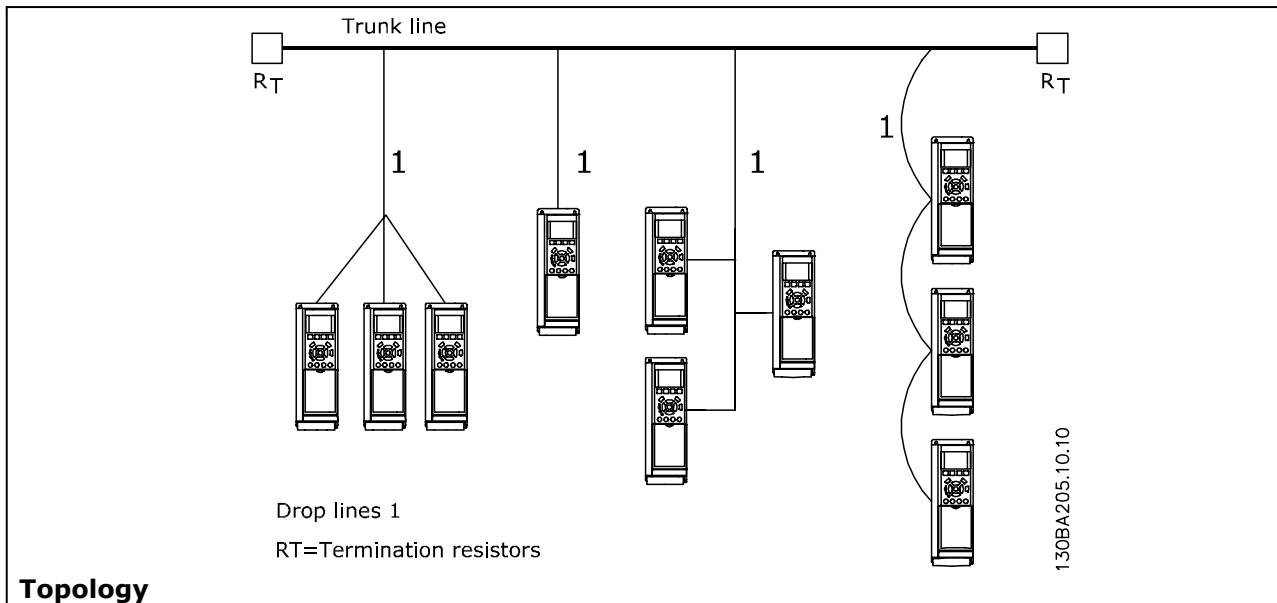

Assumptions

These operating instructions assume that you are using a Danfoss FC 300 frequency converter with CANopen. It is also assumed that as master you are using a PLC or PC equipped with a serial communication card supporting all the CANopen communication services required by your application. Furthermore, it is assumed that all requirements stipulated in the CANopen standard as well as those set up in the AC Drive Profile and those pertaining to the VLT frequency converter are strictly observed as well as all limitations therein fully respected.

Hardware

These operating instructions relate to the CANopen option type nos. 130B1103

Background Knowledge

The Danfoss CANopen option is designed to communicate with any master abiding by the CANopen standard. It is therefore assumed that you have full knowledge of the PC or PLC you intend to use as a master in your system. Any questions pertaining to hardware or software produced by any other manufacturer is beyond the scope of these operating instructions and is of no concern to Danfoss. If you have questions about how to set up master - master communication or communication to a non-Danfoss slave, please consult the appropriate documentation.

FC 300-related Literature

The following literature is available for the FC 300 series.

Title	Literature no.
FC 300 Operating Instructions	MG.33.AX.YY
FC 300 Design Guide	MG.33.BX.YY
FC 300 Profibus Operating Instructions	MG.33.CX.YY
FC 300 CANopen Operating Instructions	MG.33.DX.YY
FC 300 CANopen Operating Instructions	MG.33.JX.YY
FC 300 MCT 10 Software Dialogue	MG.33.EX.YY
Profibus DP V1 Design Guide	MG.90.EX.YY

Please also refer to <http://www.danfoss.com/drives> for frequently asked questions and additional information.

Abbreviations

- I n t r o d u c t i o n -

ACK	ACKnowledge
BOC	Bus Off Counter
BOOL	BOOLean expression
CAN	Controller Area Network
CSMA/CA	Carrier Sense Multiple Access/Collision Avoidance
CTW	Control Word
EDS	Electronic Data Sheet
EMC	Electromagnetic Compatibility
ETR	Electronic Thermal Relay
FIFO	First In First Out
HF	High Frequency
HPFB	High Performance Field Bus
I/O	Input/Output
ISO	International Standards Organization
LCD	Liquid Crystal Display
LCP	Local Control Panel
LED	Light Emitting Diode
LSB	Least Significant Bit
MAV	Main Actual Value
MRV	Main Reference Value
MSB	Most Significant Bit
N/A	Not Applicable
OSI	Open Systems Interconnection
PC	Personal Computer
PCD	Process Data
PIW	Peripheral Input Word
PLC	Programmable Logic Control
PNU	Parameter Number
PPO	Parameter-Process Data Object
QW	Peripheral Output Word
SINT	Signed Integer
STW	Status Word
VSD	Variable Speed Drive
UDINT	Unsigned Double Integer
UNIT	Unsigned Integer
USINT	Unsigned Short Integer

From Requirement Specification:

CiA	CAN in Automation
CMS	CAN Message Specification (same as FMS for Profibus or PMS for Interbus)
COB	Communication Object
COB-ID	Communication Object Identifier; a unit of transportation in a CAN network. Data must be sent across a CAN network inside a COB
DeviceNet	DeviceNet is a high level protocol, like CANopen, based on CAN; it is made by Allen Bradley
EDS	Electronic Data Sheet (file of parameter descriptions for the bus)
NMT	Network Management
OD	Object Directory
PCP	Peripherals Communication Protocol
PDO	Process Data Object
RPDO	Receive Process Data Object
pv	Profile velocity mode
RPM	Revolutions per minutes; unit for the speed of a revolving motor
RTR	Transmission request frame
SDO	Service Data Object
SYNC	Object for synchronization of process data
TPDO	Transmit Process Data Object
tq	Profile torque mode
vi	velocity mode

- I n t r o d u c t i o n -

How to Install

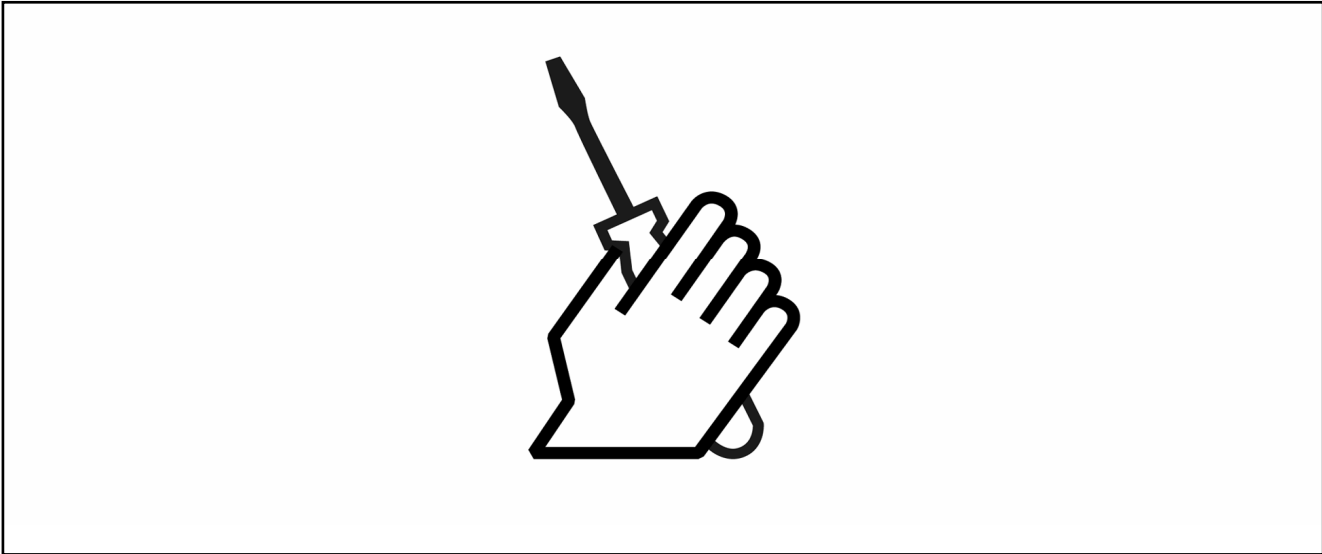

Cabling

Cable Lengths

Cable Specifications				
Bus length in meters	Bus cable		Termination resistor Ω	Baudrate Kbit/s
	Resistance $m\Omega/m$	Cross section mm^2		
0-40	70	0.25-0.34	124	1000 (up to 30m)
40-300	<60	0.34-0.6	150-300	>500 (up to 100m)
300-600	<40	0.5-0.6	150-300	>100 (up to 500m)
600-1000	<26	0.75-0.8	150-300	>50 (up to 1000m)

Cable Specifications

The cable used should be according to the specifications.

Be aware that the "Flat Cable" is an unshielded cable type, and is not suited for use with frequency converters.

- How to Install -

EMC Precautions

The following EMC precautions are recommended in order to achieve interference-free operation of the CANopen network. Additional EMC information is available in the FC 300 series Operating Instructions and FC 300 Design Guide.

**NB!:**

Relevant national and local regulations, for example regarding protective earth connection, must be observed.

The CANopen communication cable must be kept away from motor and brake resistor cables to avoid coupling of high frequency noise from one cable to the other. Normally a distance of 200 mm (8 inches) is sufficient, but it is generally recommended to keep the greatest possible distance between the cables, especially where cables run in parallel over long distances. If the CANopen cable has to cross a motor and brake resistor cable they must cross each other at an angle of 90 degrees.

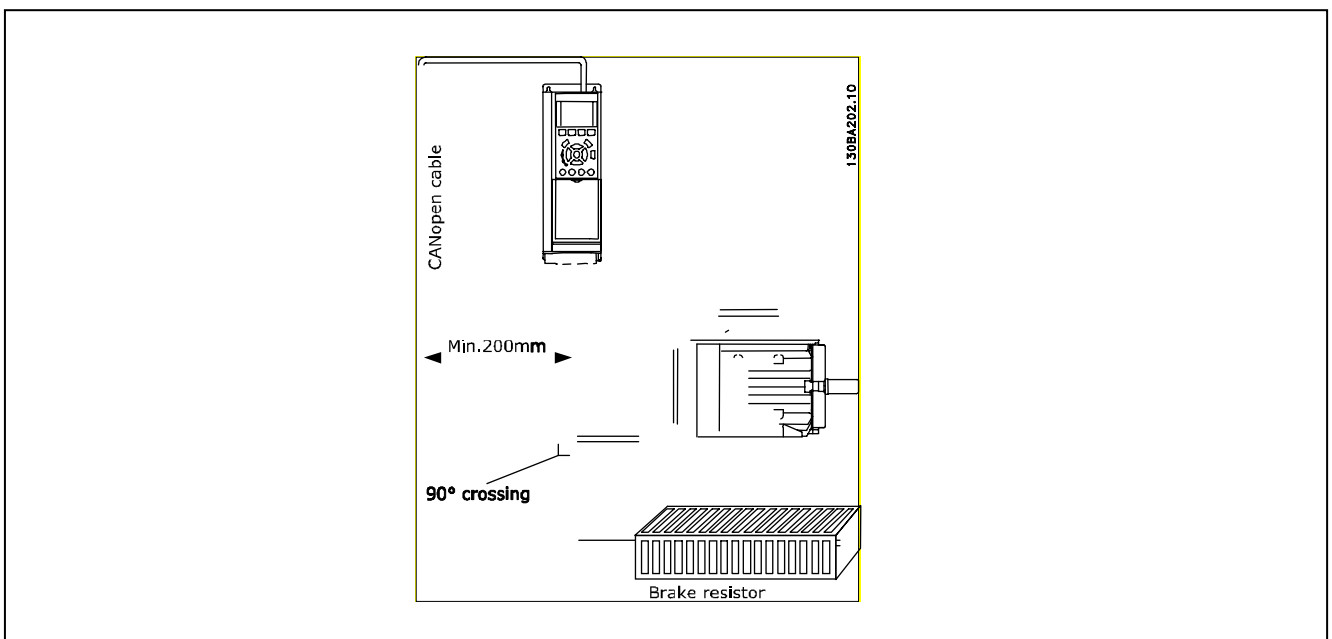

- H o w t o I n s t a l l -

Connection of the Cable Screen

Danfoss recommends connection of the screen of the CANopen cable to ground at both ends of the cable at every CANopen station (see Danfoss recommendation for further details). Low impedance ground connection of the screen is very important, also at high frequencies. Achieve this by connecting the surface of the screen to ground, for example by means of a cable clamp or a conductive cable gland. The frequency converter package includes various clamps and brackets to enable a proper ground connection of the CANopen cable screen. The screen connection required for CE and EMC compliance is shown in the following drawing.

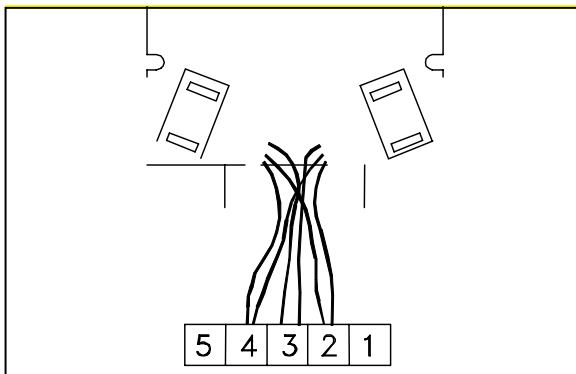

Recommendation

The Screen must be connected to ground at only one point on the network.



NB!: Please note that this recommendation conflicts with the correct EMC installation.

Earth Connection

It is important that all stations connected to the CANopen network are connected to the same earth potential. The earth connection must have a low HF (high frequency) impedance. This can be achieved by connecting a large surface area of the cabinet to ground, for example by mounting the VLT frequency converter on a conductive rear plate.



NB!: Particularly when there are long distances between the stations in a CANopen network, it may be necessary to use additional potential equalizing cables, connecting the individual stations to the same earth potential.

Pin no.	Terminal	Colour	Name
1	-	-	Reserved
2	CAN_L	Blue	CAN LOW
3	Drain	(bare)	Screen
4	CAN_H	White	CAN HIGH
5	-	-	Reserved

CANopen Connection

It is essential to terminate the bus line properly. A mismatch of impedance may result in reflections on the line that will corrupt data transmission. The CANopen control card is provided with a plug-cable connector. When a plug connector is used as a splice between two trunk lines, the removal of devices will not sever the network. If required, the developer must provide strain relief. In current installations of this type of connector, the strain relief is attached to the product.



NB! Install wires only when the network is inactive. This will prevent problems such as shorting the network supply or disrupting communications.

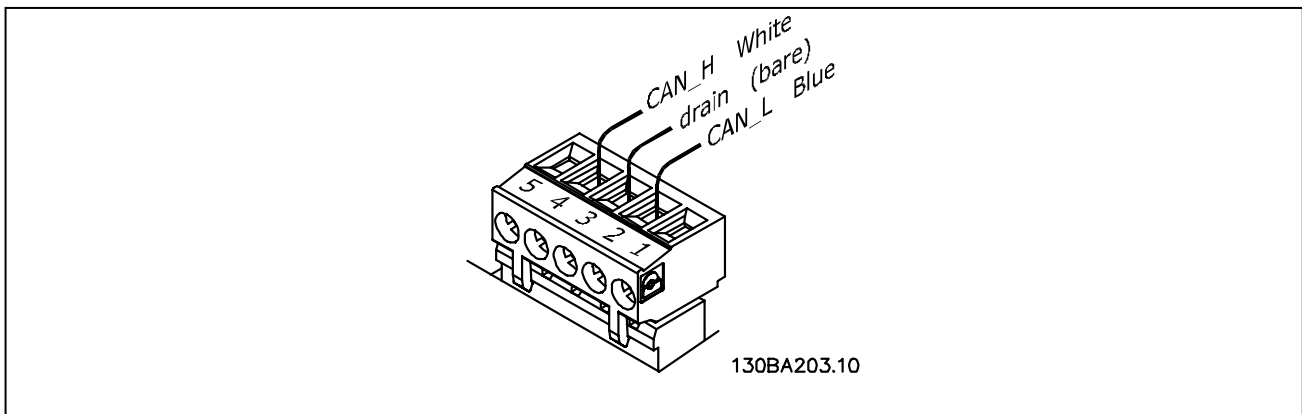

CANopen Termination

Termination resistors should be installed at each end of the bus line. The resistors must be mounted between terminal 2 (CAN_L) and terminal 4 (CAN_H) and should have the following specification:

120 Ohm, 1 % Metal film, 1/4 Watt

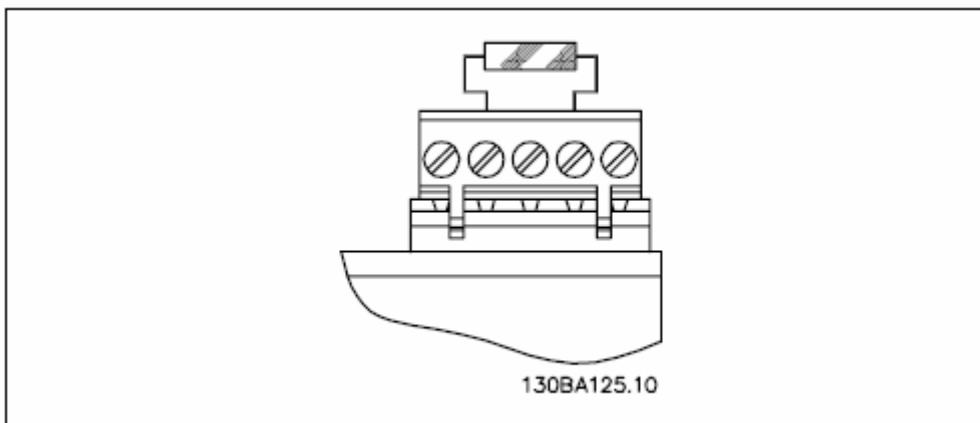

Installation of Option in Drive

To install a fieldbus option in the drive you will need:

- The fieldbus option
- Fieldbus option adaptor frame for the FC 300. This frame is deeper than the standard frame, to allow space for the fieldbus option beneath.
- Cable holders

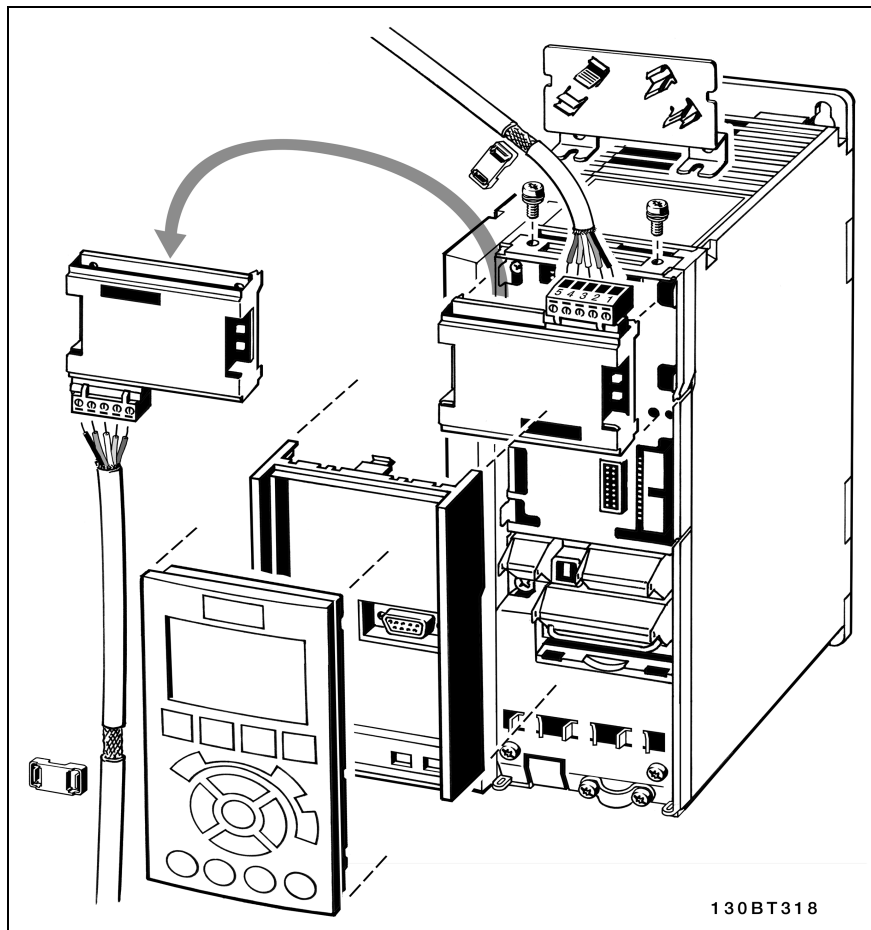

Instructions:

- Remove the LCD panel from the FC 300.
- Remove the frame located beneath and discard.
- Push the option into place. Two positions are possible, with cable terminal facing either up or down. The cable up position is often most suitable when several frequency converters are installed side by side in a rack, as this position permits shorter cable lengths.
- Push the fieldbus option adaptor frame for the FC 300 into place.
- Replace the LCD panel.
- Attach cable.
- Fasten the cable in place using cable holders. The FC 300 top surface has pre-drilled threaded holes for attaching the cable holders to the unit.
- If an option is installed after initial power-up the frequency converter will be tripped and display: *Alarm 67 Option Change*.

How to Configure the System

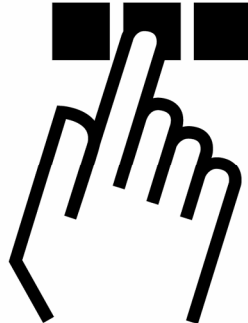

Set the CANopen Address

All CANopen stations that are connected to the same bus network must have a unique station address. The CANopen address of a FC 300 can be selected via:

- Parameter 10-02 *Drive Node ID* (default 127)

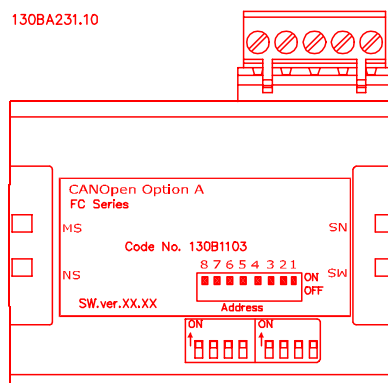

NB!:

Switch off the power supply before changing the hardware switches.

Set the CANopen Address via Parameter 10-02 *Drive Node ID*:

The address can be set via parameter 10-02 *Drive Node ID*. The hardware switches has no functionality. The address change will come into effect at the next power-up.

Set the CANopen Baud Rate

All CANopen stations connected to the same bus network must have the same Baud rate. The baud rate of an FC 300 can be selected via:

- Parameter 10-01 *Baudrate Select* (default 125 kbps)

Set the CANopen Baud Rate via Parameter 10-01 *Baudrate select*:

The baud rate can be set via parameter 10-01 *Baudrate select*. Hardware switches have no functionality (disabled)

Configure the Network

Network Management NMT

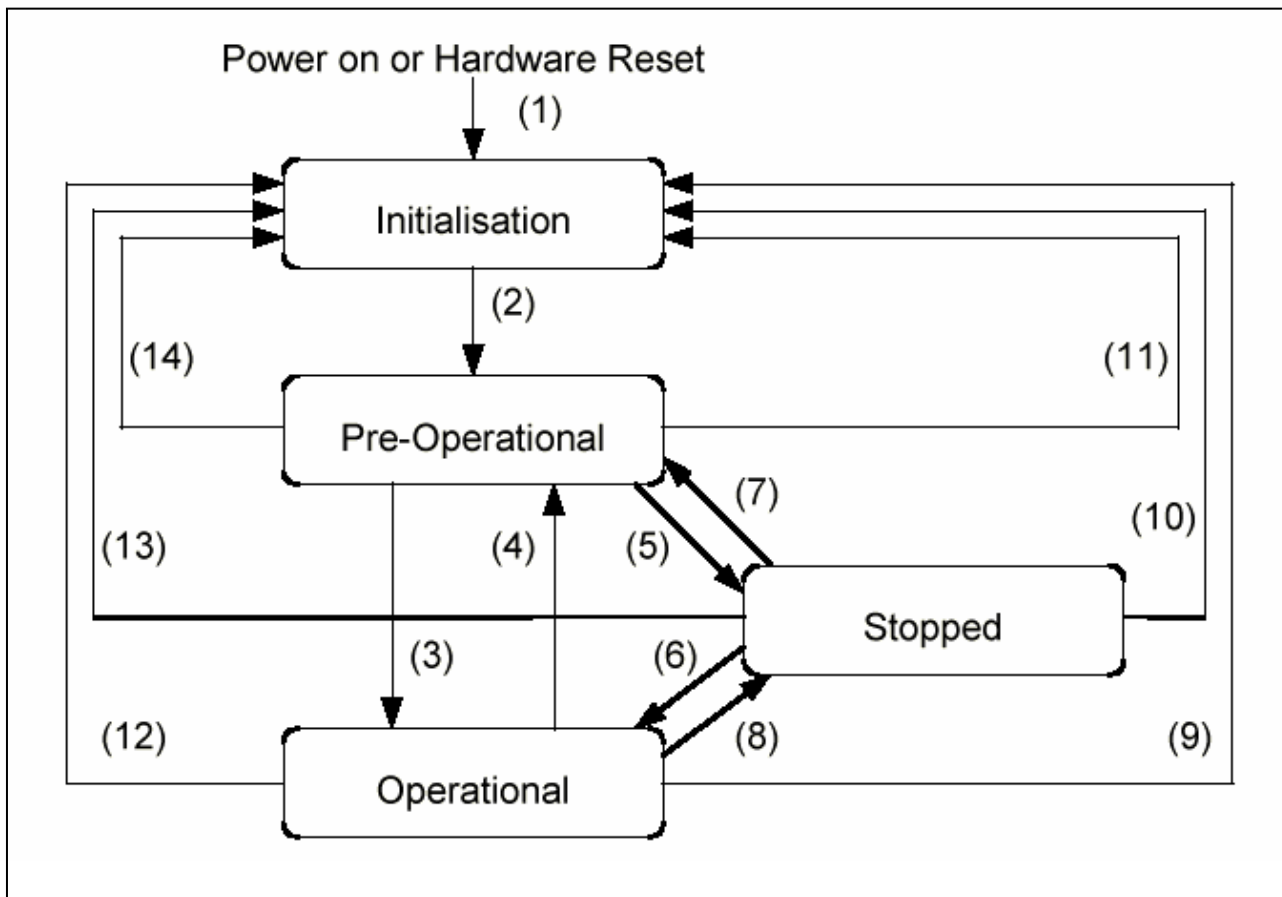

1005h, 1006h, 1007h Synchronization Object (SYNC)

The SYNC producer broadcasts the Synchronization Object periodically. This SYNC provides the basic network clock. In order to guarantee timely access to the CAN bus the SYNC is given very high priority identifiers (1005h, 1006h, 1007h). Devices which operate synchronously must use the SYNC object to synchronize their own timing with that of the Synchronization Object producer.

1017h Producer Heartbeat Time

The heartbeat acts as an error control service to detect a failure in the CAN network. The heartbeat mechanism for a device is established through cyclically transmitting a message by a heartbeat producer. One or more devices in the network are aware of this heartbeat message. If the heartbeat cycle fails for the heartbeat producer the local application on the heartbeat consumer will be informed about that event.

The producer heartbeat time defines the cycle time of the heartbeat. The producer heartbeat time remains at default 0 if it is not used.

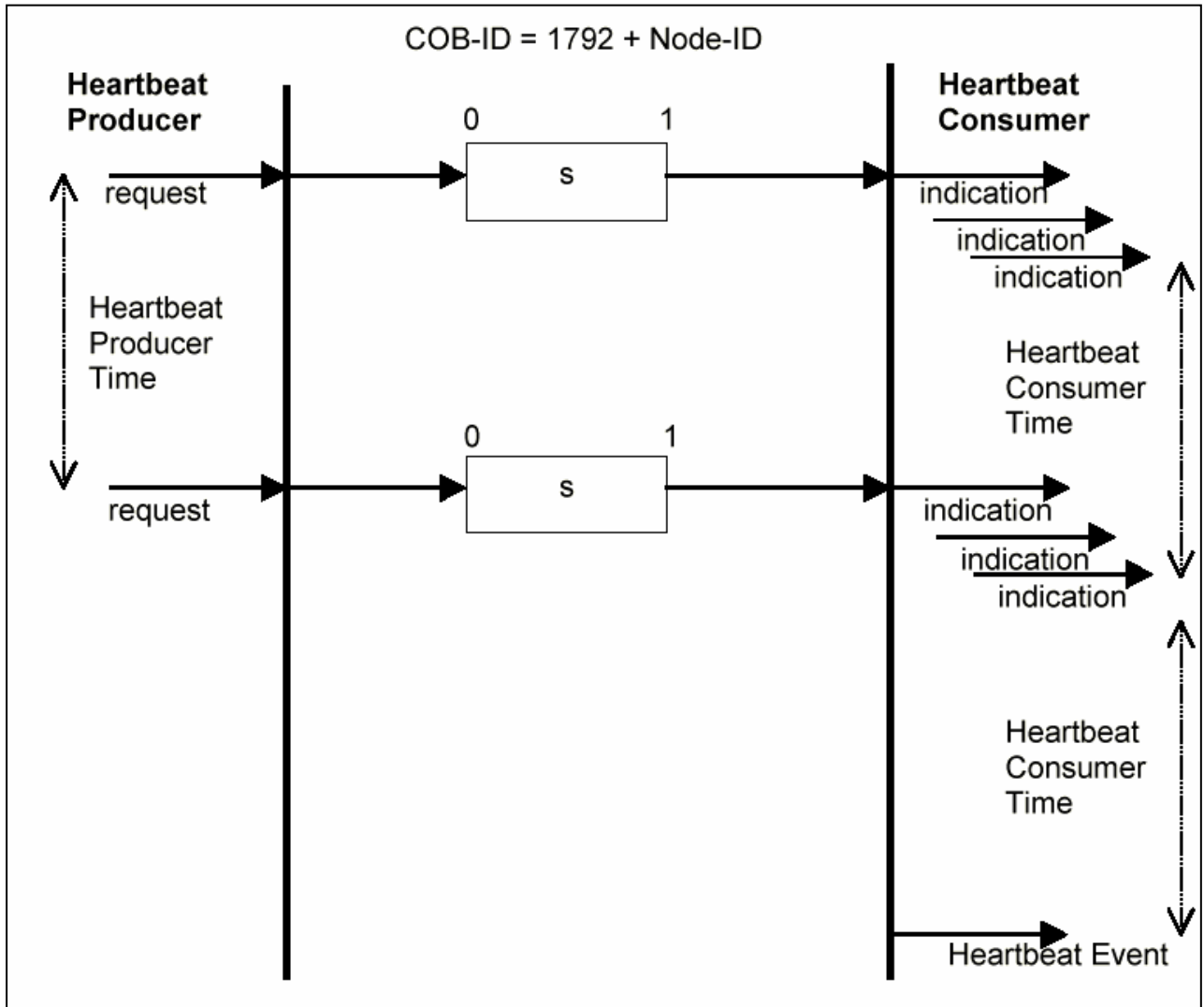

1014h, 1015h Emergency object (EMCY)

The emergency object is used to signal error states, and is sent automatically if an alarm in the drive occurs containing the data described below. If the alarm is removed, another emergency telegram is sent out with the contents 0, signalling the end of the device’s alarm state.

The behaviour of the EMCY object can be configured via objects 1014h & 1015h and par. 8-07 *Diagnosis Trigger*.

If par. 8-07 *Diagnosis Trigger* is set to “OFF”, then the EMCY will not be sent at all; if it is set to “trigger alarms”, then it is sent if an alarm occurs; if it is set to “trigger alarms and warnings” then it is sent if an alarm or a warning occurs.

The EMCY always consists of 8 bytes with the full data as described below.

byte 0	byte 1	byte 2	byte 3	byte 4	byte 5	byte 6	byte 7
EMCY code (OBJ 1003h/SI 1)		OBJ 1001h	vendor specific info				
			drive alarm word		drive warning word		reserved

Configure the FC 300

VLT Parameters

Pay particular attention to the following parameters when configuring an FC 300 with a CANopen interface. Please refer to the Parameters chapter for more details of each parameter.

- Parameter 0-40 [*Hand on*] key on LCP.
If the Hand button on the FC 300 is activated, control of the drive via the CANopen interface is disabled. After initial power-up the FC 300 will automatically detect whether a fieldbus option is installed in slot A, and set parameter 8-02 *Control word source* to [Option A]. If an option is added to, changed in or removed from an already commissioned drive, it will not change par. 8-02 but will enter Trip Mode, and the frequency converter will display an error.
- Parameter 8-10 *Control word profile* (see section: *How to Control the FC300*).
Choose between the Danfoss FC Profile and the DSP 402 profile for CANopen.
- Parameters 8-50 to 8-56 (see *Parameters* section).
Selection of how to gate the CANopen control commands with digital input command of the control card.

**NB!:**

When parameter 8-01 *Control Site* is set to [2] *Control word only*, then the settings in parameters 8-50 to 8-56 will be overruled, and will all act on Bus-control.

- Parameters 8-03 to 8-05. The reaction in the event of a bus time out is set via these parameters.
- Parameter 10-01 *Baud rate*. Default is 125 kbps.
- Parameter 10-02 *Drive Node ID*. Default is 127.

LEDs

The CANopen control card contains two bi-colour (green/red) LEDs for each connector hook-up port, to indicate the state of the device and the network respectively. For details of the range of communications status indicated by the LEDs, please refer to the *Troubleshooting* chapter.

How to Control the FC300

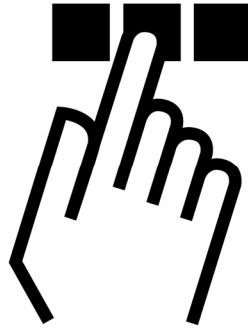

Device Profile

Each device (object) is uniquely defined using an Object Dictionary description. In the CANopen protocol the following object types are defined:

Object Index Range (hex)	Object Type
0000	Not used
0001-001F	Static Data Types
0020-003F	Complex Data Types
0040-005F	Manufacturer Specific Data Types
0060-007F	Device Profile Specific Data Types
0080-009F	Device Profile Specific Complex Data Types
00A0-0FFF	Reserved for further use
1000-1FFF	Communication Profile Area
2000-5FFF	Manufacturer Specific Profile Area
6000-9FFF	Standardised Device Profile Area
A000-FFFF	Reserved for further use

Communication in CANopen

Communication with the frequency converter in CANopen is achieved via Service Data Objects (SDOs), Process Data Objects (PDOs) and Network Management (NMT).

- How to Control the FC 300 -

Basic structure of the CAN data telegram

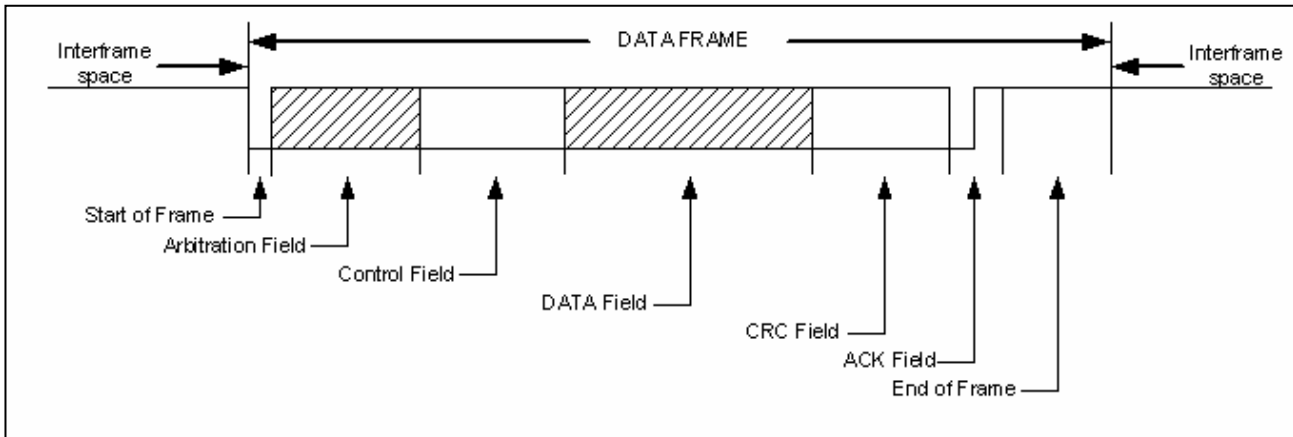

Each communication object has a unique identity (COB-ID) comprising the function code and the node ID.

COB identifier (COB-ID):

10	9	8	7	6	5	4	3	2	1
Function				Node ID					

PDOs represent real-time process data with high priority.
 SDOs represent non-time-critical data and are used to configure the frequency converter.
 NMT functions monitor the network stability and include synchronisation, detection of faults and emergency message transmission.

Comparison of functionality of PDOs and SDOs:

Process Data Objects (PDO)	Service Data Objects (SDO)
0-8 bytes of data	Client-Server communication Always 8 bytes of data If fewer than 8 bytes are used, the remainder of the object is filled with 0's. SDOs permit transmission of larger volumes of data by segmentation.
Represent process data	Used to configure the device by accessing the Object Directory (OD)
Consist of CAN ID and data	
Represent real-time data of high priority	Non-time-critical data, of low priority
Broadcast unacknowledged on the bus, no protocol overhead	Always access the OD
Content is fixed by the CAN ID, configured by the user.	

Broadcast functions	Node functions
NMT	EMCY
SYNC	PDO1 (write), PDO1 (read)
TIME STAMP	PDO2 (write), PDO2 (read)
	PDO3 (write), PDO3 (read)
	PDO4 (write), PDO4 (read)
	SDO (write), SDO (read)
	NMT Error Control

Communication Profile Area (1000h-1FFFh)

This section describes the general layout of the CANopen communication area which is supported. The process data objects are defined in this area.

Communication object overview

Index (hex)	Object (Symbolic Name)	Name	Type	read/write
1000	VAR	Device type	UNSIGNED32	ro
1001	VAR	Error register	UNSIGNED8	ro
1002	VAR	Manufacturer status register	UNSIGNED32	ro
1003	ARRAY	Pre-defined error field	UNSIGNED32	ro
1005	VAR	COB-ID SYNC	UNSIGNED32	rw
1008	VAR	Manufacturer device name	VISIBLE_STRING	constant
1009	VAR	Manufacturer hardware version	VISIBLE_STRING	constant
100A	VAR	Manufacturer software version	VISIBLE_STRING	constant
100C	VAR	Guard time	UNSIGNED16	rw
100D	VAR	Life time factor	UNSIGNED8	rw
1010	ARRAY	Store parameters	UNSIGNED32	rw
1011	ARRAY	Restore default parameters	UNSIGNED32	rw
1014	VAR	COB-ID EMCY	UNSIGNED32	rw
1017	VAR	Producer heartbeat time	UNSIGNED16	rw
1018	RECORD	Identity Object	Identity (23h)	ro
1201	RECORD	2 nd Server SDO parameter	SDO Parameter (22h)	rw
.....
127F	RECORD	128 th Server SDO parameter	SDO Parameter (22h)	rw
1280	RECORD	1 st Client SDO parameter	SDO Parameter (22h)	rw
1281	RECORD	2 nd Client SDO parameter	SDO Parameter (22h)	rw
.....
12FF	RECORD	128 th Client SDO parameter	SDO Parameter (22h)	rw
1400	RECORD	1 st Receive PDO control word description	PDO CommPar (20h)	rw
.....
1406	RECORD	6 th Receive PDO description for vi	PDO CommPar (20h)	rw
1406-15FF	RECORD	Reserved for receive PDO Parameter		
1600	RECORD	1 st receive PDO Control word value	PDO Mapping (21h)	rw
.....
1605	RECORD	6 th Receive PDO values for vi	PDO Mapping (21h)	rw
1606-17FF	RECORD	Reserved for receive PDO Mapping		
1800	RECORD	1 st transmit PDO status word description	PDO CommPar (20h)	rw
.....
1805	RECORD	6 th transmit PDO description for vi	PDO CommPar (20h)	rw
1806-19FF	RECORD	Reserved for transmit PDO Parameter		
1A00	RECORD	1 st transmit PDO status word value	PDO Mapping (21h)	rw

- H o w t o C o n t r o l t h e F C 3 0 0 -

.....
1A05	RECORD	5 th transmit PDO values for vi	PDO Mapping (21h)	rw
1A06-1BFF	RECORD	Reserved for transmit PDO Mapping		

1000h Device type

This object describes the type of device and its functionality. It is composed of a 16-bit field describing the device profile used, and a second 16-bit field providing additional information about optional functionality of the device.

Additional Information		Device Profile Number
Mode bits	Type bits	Bits
31.. 24	23.. 16	15.. 0
0	1 (<i>frequency converters</i>)	402

1001h Error register

This object is the error register of the device. The device can map internal errors in this byte. This entry is mandatory for all devices, and is a part of the Emergency Object. Each bit of the error register is reserved for a specified group of errors (alarms). Only bit 0 is supported. The other error information can be read with object 603Fh, Error Code.

Content of error register:

Bit	Meaning
0	generic error
1	current
2	voltage
3	temperature
4	communication error (overrun, error state)
5	device profile specific
6	Reserved (always 0)
7	Danfoss FC

1002h Manufacturer status register

The contents of this object are completely manufacturer specific, and inform of the state of the drive network:

Bit	Meaning
0 (1?)	Stopped
1 (2?)	Pre-operational
2 (3?)	Operational

1003h Predefined error field

Holds the error that has occurred on the drive. Setting index 0 to 0 will erase the field.

Index	Meaning
1003h 0	Number of stored errors
1003h 1	Current error
1003h 2	Last error

- H o w t o C o n t r o l t h e F C 3 0 0 -

Please refer to the section *SDO Abort Codes* in the chapter *How to Access FC 300 Parameters* for a list of error codes that can be recorded in this object.

1005h COB-ID Sync Message object

This index defines the COB-ID of the Synchronization Object (SYNC). It also defines whether the device generates the SYNC.

The structure of the SYNC COB-ID is:

Bit	Value	Meaning
31 (MSB)	X	do not care
30	0 1	Device does not generate SYNC message Device generates SYNC message (not supported)
29	0 1	11-bit ID (CAN 2.0A) 29-bit ID (CAN 2.0B)
28 - 11	0 X	if bit 29=0 if bit 29=1: bits 28-11 of 29-bit-COB-ID
10-0 (LSB)	X	bits 10-0 of COB-ID

Bits 29, 30 must be static (not changeable). If a device is not able to generate SYNC messages, an attempt to set bit 30 will generate an abort message (abort code: 0609 0030h).

Devices supporting the standard CAN frame type only will either ignore attempts to change bit 29 or respond with an abort message (abort code: 0609 0030h).

The first transmission of SYNC object starts within 1 sync cycle after setting Bit 30 to 1.

1008h Manufacturer Device Name

This object contains the device name as defined in par.15-40

1009h Manufacturer Hardware Version

This object contains the Danfoss FC hardware version

100Ah Manufacturer Software Version

This object contains the Danfoss software version as displayed in par.15-49.

100Ch Guard time

This object is used in node guarding, an error control service used in addition to the heartbeat mechanism to detect failure in the CAN network.

Node guarding provides the only possible verification of the master's availability on the bus, for the drive's timeout functionality.

This object contains the gap between two master requests in ms.

100Dh Life time factor

This object contains the lifetime factor used in node guarding. This factor multiplied with the contents of 0100Ch defines the time after which the slave has to be polled by the master's node guarding request. If this time has elapsed without the slave being polled by a guard telegram, a warning 34 will be issued by the slave.

1010h Store parameters

In the standard configuration, the contents of parameters written via fieldbus are stored in volatile memory, i.e. the changed data will be lost after a power cycle. This index permits non-volatile storage of all drive parameters which have been changed.

- H o w t o C o n t r o l t h e F C 3 0 0 -

Index, sub-index	Meaning
1010h 0	Largest sub-index supported
1010h 1	Save option parameters
1010h 4	Save all parameters, including option parameters (Edit Set-up)
1010h 5	Save all parameters, including option parameters (all set-ups)

Writing the value "save" (0x65766c173) to sub-index 5 will save all drive parameters of all set-ups into non-volatile memory, all other values must be rejected. Sub-index 4 will do the same for the Edit Set-up. This is handled via par. 10-31 *Store data values*.

1011h Restore default parameters

Use this object to set the drive to factory default, by writing the value "load" to sub-index 1. The parameters will be set to default after the next power cycle, which has to be initiated manually.

Index, sub-index	Meaning
1011h 0	Largest sub-index supported
1011h 1	Restore all default parameters

1014h COB ID emergency object

This object defines the COB-ID under which the emergency object (EMCY) is sent.

Index, sub-index	Meaning
1014h 0	COB ID

1018h Identity object

This object contains general information about the device.

The Vendor ID (sub-index 1h) contains a unique value allocated to each manufacturer.

The manufacturer-specific Product code (sub-index 2h) identifies a specific device version.

The manufacturer-specific Revision number (sub-index 3h) consists of a major revision number and a minor revision number. The major revision number identifies a specific CANopen behavior. If the CANopen functionality is expanded, the major revision has to be incremented. The minor revision number identifies different versions with the same CANopen behavior.

Index, sub-index	Meaning
1018h 0	Number of entries
1018h 1	Vendor ID
1018h 2	Product code
1018h 3	Revision number (major revision number and minor revision number)
1018h 4	Serial number

DSP 402 Control Profile

Control Word according to DSP 402 profile. (Par. 8-10 = DSP 402 profile)

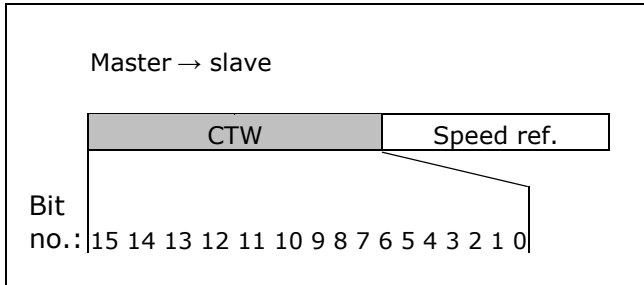

Bit	Bit value = 0	Bit value = 1
00	Switch off	Switch on
01	Disable voltage	Enable voltage
02	Quick stop	run
03	Disable operation	Enable operation
04	Disable ramp	Enable ramp
05	Freeze	Run enable
06	Ramp stop	Start
07	No function	Reset
08	Reserved	
09	Reserved	
10	Reserved	
11	Jog 1 OFF	Jog1 ON
12	Reserved	
13	Setup select (LSB)	
14	Setup select (MSB)	
15	Forward	Reversing

Explanation of the Bits:

Bit 00, Switch OFF/ON:

Bit 00= "0" execute transition 2, 6 or 8.
 Bit 00 = "1" execute transition 3.

Bit 01, Disable/Enable Voltage:

Bit 01= "0" execute transition 9, 10 or 12.
 Bit 01 = "1" = "Enable Voltage".

Bit 02, Quick stop/Run:

Bit 02= "0" execute transition 7, 10 or 11.
 Bit 02 = "1" = Quick stop not active.

Bit 03, Disable/enable Operation:

Bit 03= "0" execute transition 5.
 Bit 03 = "1" = "Enable operation".

Bit 04, Quick-stop/ramp:

Bit 04= "0" execute transition 7 or 11, Quick stop.

Bit 04 = "1" = Enable ramp.

Bit 05, Freeze output frequency/run enable:

Bit 05 = "0" means that the given output frequency is maintained even if the reference is changed.

Bit 05 = "1" means that the frequency converter is again able to regulate, and the given reference is followed.

Bit 06, Ramp stop/start:

Bit06= "0" The VLT controls the motor down to stop.

Bit 01 = "1" = Start command to the VLT is given.

Bit 07, No function/reset:

Reset of trip.

Bit 07 = "0" means that there is no reset.

Bit 07 = "1" means that a trip is reset.

Bit 08, 09 and 10:

DSP402 reserved.

Bit 11, Jog 1 OFF/ON:

Activation of pre-programmed speed in parameter 8-90 (Bus JOG 1).

JOG 1 is only possible if Bit 04 = "0", and bit 00 to 03 = "1".

Bit 12:

Danfoss reserved.

Bits 13/14, Selection of Setup:

Bits 13 and 14 are used for choosing among the four menu Setups in accordance with the following table:

Bit 14	Bit 13	Setup
0	0	1
0	1	2
1	0	3
1	1	4

Bit 15, Forward/reversing:

Bit 15 = "0" leads to no reversing.

Bit 15 = "1" leads to reversing.

Note: In factory setting reversing is set to [digital] in par. 8-54 *Reversing select*.

FC 300 Interbus
- How to Control the FC 300 -

Status Word according to DSP 402 profile.

(Par. 8-10 = DSP 402 profile)

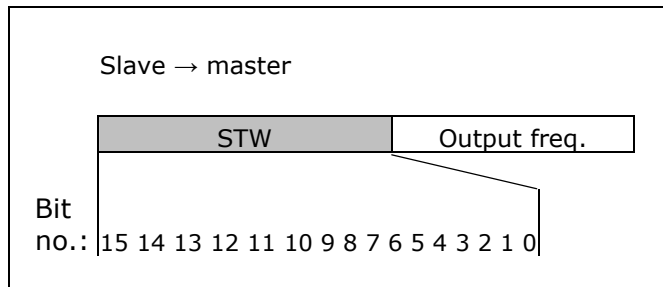

Bit	Bit value = 0	Bit value = 1
00	Not ready to switch ON	Ready to switch ON
01	Switched OFF	Switched ON
02	Operation disabled	Operation enabled
03	No malfunction	Malfunction
04	Voltage disabled	Voltage enabled
05	Quick stop	Run
06	Switch on disable	Switch on enable
07	No warning	Warning
08	Reserved	
09	Remote disabled	Remote enabled
10	Set point not reached	Set point reached
11	Speed limit not active	Speed limit active
12	Reserved	
13	Reserved	
14	Not running	Running
15	Reserved	

Explanation of the Bits:

Bit 00, Not ready to switch on/Ready to switch on:

Bit 00 = "0" state less than "Ready to switch on".

Bit 00 = "1" state at least = "Ready to Switch on".

Bit 01, Switch off/Switch on:

Bit 00 = "0" state less than "Switched on".

Bit 00 = "1" state at least = "Switched on".

Bit 02, Operation disable/Operation enable:

Bit 00 = "0" state less than "Operation enable".

Bit 00 = "1" state at least = "Operation enable".

Bit 03, No fault/trip:

Bit 03 = "0" means that the drive is not in a fault condition.

Bit 03 = "1" means that the drive has tripped and needs a reset signal in order to run.

Bit 04, Voltage disable/Voltage enable:

Bit 04 = "0" means that control word bit 01 = "1".

Bit 04 = "1" means that control word bit 01 = "0".

Bit 05, Quick stop/Run:

Bit 05 = "0" means that control word bit 02 = "1".

Bit 05 = "1" means that control word bit 02 = "0".

Bit 06, Start enable/Start disable:

Bit 06 = "0" state is not "Switch on disable".

Bit 06 = "1" state = "Switch on enable".

Bit 07, No warning/Warning:

Bit 07 = "0" means that there is no warning situation.

Bit 07 = "1" means that a warning has occurred.

Bit 08, Danfoss reserved:

Bit 09, Remote disable/Remote enable:

Bit 09 = "0" means that the drive has been stopped by means of the stop key on the LCP, or that [Local] has been selected in parameter 3-13 *Reference site*.

Bit 09 = "1" means that it is possible to control the drive converter via the serial port.

Bit 10, Set point not reached/Set point reached:

Bit 10 = "0" means that the actual motor speed is different from the speed reference set. This can be the case while the speed is ramped up/down during start/stop.

Bit 10 = "1" means that the present motor speed equals the speed reference set.

Bit 11, Speed limit not active/speed limit active:

Bit 11 = "0" means that the output frequency is out of the range set in par. 4-11/4-12 *Motor Speed low Limit RPM/Hz* or par. 4-13/4-14 *Motor Speed high Limit RPM/Hz*.

Bit 11 = "1" means that the output frequency is within the mentioned range.

- H o w t o C o n t r o l t h e F C 3 0 0 -

Bit 12, DSP 402 reserved.

Bit 13, DSP 402 reserved.

Bit 14, Running/Not running:

Bit 14 = "0" means that the motor is not running.

Bit 14 = "1" means that the drive has a valid start signal or that the output frequency is greater than 0 Hz.

Bit 15, Danfoss reserved.

Standardised Device Profile Area

State transitions

Transition	State	Control word	Status word	Action
	Start condition	0000	0000	
0	Startup -> Not Ready to Switch On	0000	0200	
1	Not Ready to Switch On -> Switch On Disabled	0000, 0001	0240	
2	Switch On Disabled -> Ready to Switch On	0006	0231	
3	Ready to Switch On -> Switched On	0007	0233	
4	Switched On -> Operation Enabled	000F	0237	
5	Operation Enabled -> Switched On	0007	0233	Motor ramps to 0 RPM with programmed ramp down parameter
6	Switched On -> Ready to Switch On	0006	0231	
7	Ready to Switch On -> Switch On Disable	0001, 0000	0240	
8	Operation Enable -> Ready to Switch On	0006	0231	The power section is switched off immediately, and the motor is free to rotate if unbraked
9	Operation Enable -> Switch on Disable	0001, 0000	0240	The power section is switched off immediately, and the motor is free to rotate if unbraked
10	Switched On -> Switched On Disable	0001, 0000	0240	The power section is switched off immediately, and the motor is free to rotate if unbraked
11	Operation Enabled -> Quick Stop Active	0002	0207	Motor ramps to 0 RPM with programmed quick ramp parameter
11	Operation Enabled -> Quick Stop Active	0003	0217	Motor ramps to 0 RPM with programmed quick ramp parameter
12	Quick Stop Active -> Switch On Disabled	0001, 0000	0240	The power section is switched off immediately, and the motor is free to rotate if unbraked
13	All states -> Fault Reaction Active	xxxx	023F	
14	Fault Reaction Active -> Fault	xxxx	023F (0238 by Interbus)	
15	Fault -> Switch On Disabled	0000	0240	
16	Quick Stop Active -> Operation Enable (not supported)			

Danfoss FC control profile

Control Word according to FC Profile, Instances 21/22

(Par. 8-10 = FC profile)

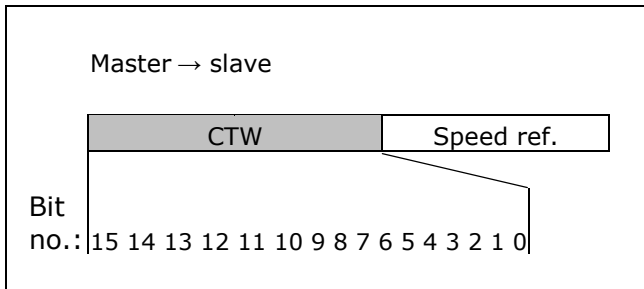

Bit	Bit value = 0	Bit value = 1
00	Reference value	external selection lsb
01	Reference value	external selection msb
02	DC brake	Ramp
03	Coasting	No coasting
04	Quick stop	Ramp
05	Hold output frequency	Use ramp
06	Ramp stop	Start
07	No function	Reset
08	No function	Jog
09	Ramp 1	Ramp 2
10	Data invalid	Data valid
11	No function	Relay 01 active
12	No function	Relay 04 active
13	Parameter set-up	selection lsb
14	Parameter set-up	selection msb
15	No function	Reverse

Explanation of the Control Bits

Bits 00/01

Bits 00 and 01 are used to choose between the four reference values, which are pre-programmed in parameter 3-10 *Preset reference* according to the following table:

Programmed ref. value	Parameter	Bit 01	Bit 00
1	3-10 [0]	0	0
2	3-10 [1]	0	1
3	3-10 [2]	1	0
4	3-10 [3]	1	1



N.B.:

In parameter 8-56 *Preset reference select* a selection is made to define how Bit 00/01 gates with the corresponding function on the digital inputs.

Bit 02, DC brake:

Bit 02 = '0' leads to DC braking and stop. Braking current and duration are set in parameters 2-01 *DC Brake current* and 2-02 *DC Braking time*.
Bit 02 = '1' leads to ramping.

Bit 03, Coasting:

Bit 03 = '0' causes the frequency converter to immediately "let go" of the motor (the output transistors are "shut off"), so that it coasts to a standstill.
Bit 03 = '1' enables the frequency converter to start the motor if the other starting conditions have been fulfilled.



N.B.:

In parameter 8-50 *Coasting select* a selection is made to define how Bit 03 gates with the corresponding function on a digital input.

Bit 04, Quick stop:

Bit 04 = '0' causes a stop, in which the motor speed is ramped down to stop via parameter 3-81 *Quick stop ramp time*.

Bit 05, Hold output frequency:

Bit 05 = '0' causes the present output frequency (in Hz) to freeze. The frozen output frequency can then be changed only by means of the digital inputs (par. 5-10 to 5-15) programmed to *Speed up* and *Speed down*.



N.B.:

If *Freeze output* is active, the frequency converter can only be stopped by the following:

- Bit 03 Coasting stop
- Bit 02 DC braking
- Digital input (par. 5-10 to 5-15) programmed to *DC braking*, *Coasting stop* or *Reset and coasting stop*.

- How to Control the FC 300 -

Bit 06, Ramp stop/start:

Bit 06 = '0' causes a stop, in which the motor speed is ramped down to stop via the selected *ramp down* parameter.

Bit 06 = '1' permits the frequency converter to start the motor, if the other starting conditions have been fulfilled.

 **N.B.:**

In parameter 8-53 *Start select* a selection is made to define how Bit 06 Ramp stop/start gates with the corresponding function on a digital input.

Bit 07, Reset:

Bit 07 = '0' does not cause a reset.

Bit 07 = '1' causes the reset of a trip. Reset is activated on the signal's leading edge, i.e. when changing from logic '0' to logic '1'.

Bit 08, Jog:

Bit 08 = '1' causes the output frequency to be determined by parameter 3-19 *Jog speed*.

Bit 09, Selection of ramp 1/2:

Bit 09 = "0" means that ramp 1 is active (parameters 3-40 to 3-47). Bit 09 = "1" means that ramp 2 (parameters 3-50 to 3-57) is active.

Bit 10, Data not valid/Data valid:

Is used to tell the frequency converter whether the control word is to be used or ignored. Bit 10 = '0' causes the control word to be ignored, Bit 10 = '1' causes the control word to be used. This function is relevant, because the control word is always contained in the telegram, regardless of which type of telegram is used, i.e. it is possible to turn off the control word if you do not wish to use it in connection with updating or reading parameters.

Bit 11, Relay 01:

Bit 11 = "0" Relay not activated.

Bit 11 = "1" Relay 01 activated, provided *Control word bit 11* has been chosen in parameter 5-40 *Function relay*.

Bit 12, Relay 04:

Bit 12 = "0" Relay 04 has not been activated.

Bit 12 = "1" Relay 04 has been activated, provided *Control word bit 12* has been chosen in parameter 5-40 *Function relay*.

Bit 13/14, Selection of set-up:

Bits 13 and 14 are used to choose from the four menu set-ups according to the following table:

Set-up	Bit 14	Bit 13
1	0	0

2	0	1
3	1	0
4	1	1

The function is only possible when *Multi-Set-ups* is selected in parameter 0-10 *Active Set-up*.

 **N.B.:**

In parameter 8-55 *Set-up select* a selection is made to define how Bit 13/14 gates with the corresponding function on the digital inputs.

Bit 15 Reverse:

Bit 15 = '0' causes no reversing.

Bit 15 = '1' causes reversing.

Note: In the factory setting reversing is set to *digital* in parameter 8-54 *Reversing select*.

Bit 15 causes reversing only when *Ser. communication, Logic or or Logic and* is selected.

- How to Control the FC 300 -

Status Word according to FC Profile (STW) Instances 21/22

(Par. 8-10 = FC profile)

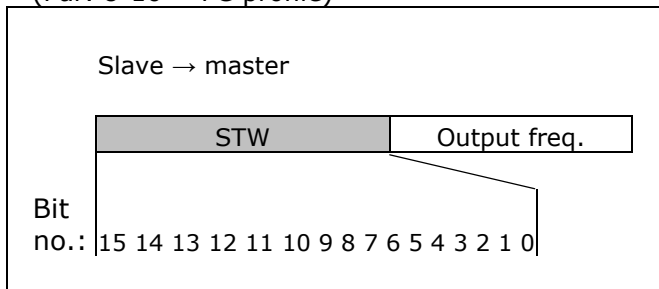

Bit	Bit = 0	Bit = 1
00	Control not ready	Control ready
01	Drive not ready	Drive ready
02	Coasting	Enable
03	No error	Trip
04	No error	Error (no trip)
05	Reserved	-
06	No error	Triplock
07	No warning	Warning
08	Speed ≠ reference	Speed = reference
09	Local operation	Bus control
10	Out of frequency limit	Frequency limit ok
11	No operation	In operation
12	Drive ok	Stopped, autostart
13	Voltage ok	Voltage exceeded
14	Torque ok	Torque exceeded
15	Timer ok	Timer exceeded

Explanation of the Status Bits

Bit 00, Control not ready/ready:

Bit 00 = '0' means that the frequency converter has tripped.
 Bit 00 = '1' means that the frequency converter controls are ready, but that the power component is not necessarily receiving any power supply (in case of external 24 V supply to controls).

Bit 01, Drive ready:

Bit 01 = '1'. The frequency converter is ready for operation, but there is an active coasting command via the digital inputs or via serial communication.

Bit 02, Coasting stop:

Bit 02 = '0'. The frequency converter has released the motor.
 Bit 02 = '1'. The frequency converter can start the motor when a start command is given.

Bit 03, No error/trip:

Bit 03 = '0' means that the frequency converter is not in fault mode.
 Bit 03 = '1' means that the frequency converter is tripped, and that a reset signal is required to re-establish operation.

Bit 04, No error/error (no trip):

Bit 04 = '0' means that the frequency converter is not in fault mode.
 Bit 04 = "1" means that there is a frequency converter error but no trip.

Bit 05, Not used:

Bit 05 is not used in the status word.

Bit 06, No error / triplock:

Bit 06 = '0' means that the frequency converter is not in fault mode.
 Bit 06 = "1" means that the frequency converter is tripped, and locked.

Bit 07, No warning/warning:

Bit 07 = '0' means that there are no warnings.
 Bit 07 = '1' means that a warning has occurred.

Bit 08, Speed≠ reference/speed = reference:

Bit 08 = '0' means that the motor is running, but that the present speed is different from the preset speed reference. It might, for example, be the case while the speed is being ramped up/down during start/stop.
 Bit 08 = '1' means that the present motor present speed matches the preset speed reference.

Bit 09, Local operation/bus control:

Bit 09 = '0' means that [STOP/RESET] is activated on the control unit, or that *Local control* in parameter 3-13 *Reference site* is selected. It is not possible to control the frequency converter via serial communication.
 Bit 09 = '1' means that it is possible to control the frequency converter via the fieldbus/ serial communication.

Bit 10, Out of frequency limit:

Bit 10 = '0', if the output frequency has reached the value in parameter 4-11 *Motor speed low limit* or parameter 4-13 *Motor speed high limit*.
 Bit 10 = "1" means that the output frequency is within the defined limits.

Bit 11, No operation/in operation:

Bit 11 = '0' means that the motor is not running.

- How to Control the FC 300 -

Bit 11 = '1' means that the frequency converter has a start signal or that the output frequency is greater than 0 Hz.

Bit 12, Drive OK/stopped, autostart:

Bit 12 = '0' means that there is no temporary over temperature on the inverter.

Bit 12 = '1' means that the inverter has stopped because of over temperature, but that the unit has not tripped and will resume operation once the over temperature stops.

Bit 13, Voltage OK/limit exceeded:

Bit 13 = '0' means that there are no voltage warnings.

Bit 13 = '1' means that the DC voltage in the frequency converter's intermediate circuit is too low or too high.

Bit 14, Torque OK/limit exceeded:

Bit 14 = '0' means that the motor current is lower than the torque limit selected in parameter 4-18 *Current limit*.

Bit 14 = '1' means that the torque limit in parameter 4-18 *Current limit* has been exceeded.

Bit 15, Timer OK/limit exceeded:

Bit 15 = '0' means that the timers for motor thermal protection and VLT thermal protection, respectively, have not exceeded 100%.

Bit 15 = '1' means that one of the timers has exceeded 100%.

Bus Speed Reference Value

The speed reference value is transmitted to the drive in a relative value in %.

The value is transmitted in the form of a 16-bit word, in integers (0-32767) the value 16384 (4000 Hex) corresponds to 100%.

Negative figures are formatted by means of 2's complement.

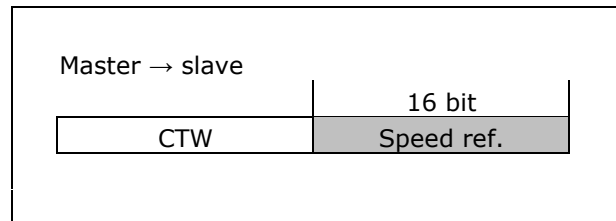

Actual Output frequency

The value of the actual speed of the motor is transmitted in the form of a 16-bit word. The value is transmitted as a whole number. Negative figures are formed by means of 2's complement.

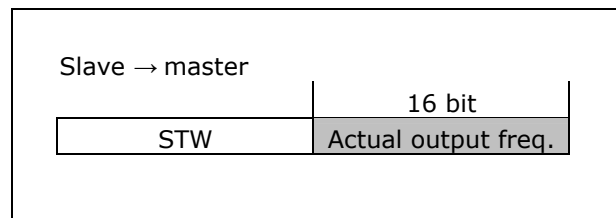

The reference is scaled the following way:

Parameter 3-00 = [0] Min - Max.

0% = par. 3-02 *Minimum Reference*.

100% = par. 3-03 *Maximum Reference*.

Parameter 3-00 = [1] -Max - +Max.

0% = 0hex.

100% = par. 3-03 *Maximum Reference*.

Process Data Objects (PDO)

There are four read (receive) PDOs and four write (transmit) PDOs for the frequency converter. Real-time process data is communicated using the PDOs.

The format of the structure is as follows:

PDO Communication Parameter Record

Index	Sub-Index	Field In PDO Communication Record	Data Type
0020H	0H	Number of supported entries in the record	Unsigned8
	1H	COB-ID used by PDO	Unsigned32
	2H	Transmission type	Unsigned8
	3H	Inhibit time	Unsigned16
	4H	CMS priority group	Unsigned8

If the device supports the identifier distribution via DBT the value on sub-index 0H is 4, otherwise it is 2 (inhibit time not supported) or 3. The COB-ID at Index 20H, Sub-Index 1H is defined using data type Unsigned32 in order to cater for 11-bit CAN Identifiers as well as for 29-bit CAN identifiers. The entry has to be interpreted as defined in the following figure and table

Structure of PDO COB-ID entry

bits	Unsigned32				LSB
	31	30	29	28-11	
11-bit-ID	0/1	0/1	0	0 0	11-bit Identifier
29-bit-ID	0/1	0/1	1	29-bit Identifier	

Description of PDO COB-ID entry

Bit number	Value	Meaning
31(MSB)	0	PDO valid
	1	PDO not valid
30	0	RTR allowed on this PDO
	1	No RTR allowed on this PDO
29	0	11-bit ID (CAN 2.0A)
	1	29-bit ID (CAN 2.0B)
28-11	0	If bit 29=0
	X	If bit 29=1: bits 28-11 of 29-bit-COB-ID
10-0 (LSB)	X	Bits 10-0 of COB-ID

The PDO valid/not valid permits selection of PDOs to be used in the operational stage. PDOs may be fully configured (e.g. by default) but not used, and therefore set to "not valid". Bits 29 and 30 may be static (not changeable), e.g. due to hardware restrictions, in which case no error is signalled on the attempt to change them.

PDO Usage

The real-time data transfer is performed by means of "Process Data Objects (PDO)". PDOs are represented by CMS objects of type "Stored-Event". Hence the transfer of PDOs is performed with no protocol overhead.

The PDOs correspond to entries in the device Object Dictionary and provide the interface to the application objects. Data type and mapping of application objects into a PDO is determined by a corresponding default PDO mapping structure within the Device Object Dictionary. If variable PDO-mapping is supported the number of PDOs and the mapping of application objects into a PDO may be transmitted to a device during the device configuration process by applying the corresponding SDO services.

Number and length of PDOs of a device is application specific and have to be specified within the device profile.

PDO Transmission Modes

The following PDO transmission modes are distinguished:

- Synchronous Transmission
- Asynchronous Transmission

The classification of synchronous and asynchronous PDOs is as follows:

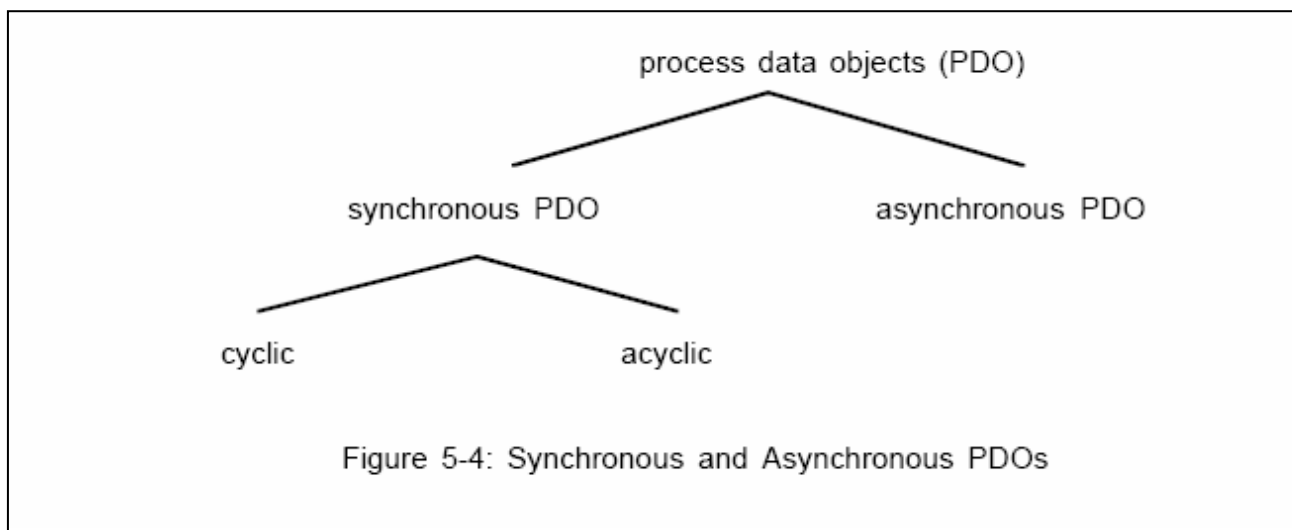

PDO Triggering Modes

The CANopen Communication Profile distinguishes two message triggering modes, Event Driven and Remotely Requested:

Event Driven

Message transmission is triggered by the occurrence of an object specific event. For synchronous PDOs this is the expiration of the specified transmission period, synchronised by the reception of the SYNC object.

For acyclically transmitted synchronous PDOs and asynchronous PDOs the triggering of a message transmission is an application specific event specified in the device profile.

Remotely requested

The transmission of asynchronous PDOs may be initiated on receipt of a remote request initiated by another device.

PDO Services

The specified PDO triggering modes of the CANopen Communication Profile are modelled by services onto the CMS object type "Stored-Events". CMS objects of type Stored-Event provide event-driven and remotely requested transmission.

According to CMS the following services on Events are relevant:

- Define Event
- Store (and immediately Notify) Event
- Read Event

The following CMS event object attributes are specified for event PDOs:

- name: according to the CMS naming conventions with <application-specific-name> = "xPDOyyy" with "yyy" as the number of the PDO, starting with 001, and with x = {"T"|"R"} for a receive or transmit PDO.
- user type: depending on the role-in-service of the device; transmitter of event data: server receiver or requester of event data: client
- class: Stored Event
- priority: application specific, suggested between [2, 5]
- data type: determined by corresponding PDO-mapping entry of the PDO
- inhibit time: application specific

Receive PDO

The following overview shows the receive (read) PDOs:

PDO No.	Index	Link to PDO (COB-ID)	Mapping Object Index	Mapping Object Name	Comment
1	1400h	1 (200h)	6040h	controlword	controls the state machine
6	1405h	2 (300h)	6040h 6042h	controlword vl_target_velocity (RPM)	controls the state machine and the nominal speed (vl)
21	1414h	3 (400h)	6040h 6042h 2F00/0h 2F00/1h	controlword vl_target_velocity (RPM) pcd 0 (p1051/0) pcd 1 (p1051/1)	
22	1415h	4 (500h)	2F00/2h 2F00/3h 2F00/4h 2F00/5h	pcd 2 (p1051/2) pcd 3 (p1051/3) pcd 4 (p1051/4) pcd 5 (p1051/5)	

1st receive PDO (M): Control Word

Index	Subindex	Comment	Default Value
1400 h	0	number of entries	3
	1	COB-ID used by PDO	200h + node-ID
	2	transmission type	255
	3	inhibit time	0
	4	not used	-
1600 h	0	number of mapped objects	1
	1	controlword	60400010 h

6th receive PDO: Target Velocity

Index	Subindex	Comment	Default Value
1405 h	0	number of entries	3
	1	COB-ID used by PDO	300h + node-ID
	2	transmission type	255
	3	inhibit time	0
	4	not used	-
1605 h	0	number of mapped objects	2
	1		60400010 h
	2		60420010 h

21st receive PDO: PCD 0 and PCD 1

Index	Subindex	Comment	Default Value
1414 h	0	number of entries	3
	1	COB-ID used by PDO	400h + node -ID
	2	transmission type	255
	3	inhibit time	0
	4	not used	-
1614 h	0	number of mapped objects	4
	1		60400010 h
	2		60420010 h
	3	process data word 1 from par. 10-50 index 0	h
	4	process data word 2 from par. 10-50 index 1	h

22nd receive PDO: PCD 2, PCD 3, PCD 4, PCD 5

Index	Subindex	Comment	Default Value
1415 h	0	number of entries	3
	1	COB-ID used by PDO	500h + node -ID
	2	transmission type	255
	3	inhibit time	0
	4	not used	-
1615 h	0	number of mapped objects	4
	1	process data word 1 from par. 10-50 index 2	h
	2	process data word 2 from par. 10-50 index 3	h
	3	process data word 1 from par. 10-50 index 4	h
	4	process data word 2 from par. 10-50 index 5	h

Transmit PDO

The transmission type is set to 255. Each new event initiates new transmit data. The inhibit time defines a delay time, after which the data will be transmitted.

The following overview shows the transmit (write) PDOs:

PDO No.	Index	Link to PDO (COB-ID)	Mapping Object Index	Mapping Object Name	Comment
1	1800h	1 (180h)	6041h	Status word	shows status
6	1805h	2 (280h)	6041h 6044h	Status word vl_control_effort (RPM)	shows the status and actual speed (vl)
21	1814h	3 (380h)	6041h 6044h 2f10h/0 2f10h/1	Status word vl_control_effort (RPM) process data word 1 (1051[0]) process data word 2 (1051[1])	
22	1815h	4 (480h)	2f10h/2 2f10h/3 2f10h/4 2f10h/5	process data word 3 (1051[2]) process data word 4 (1051[3]) process data word 5 (1051[4]) process data word 6 (1051[5])	

1st transmit PDO

Index	Subindex	Comment	Default Value
1800 h	0	number of entries	3
	1	COB-ID used by PDO	180h + node-ID
	2	transmission type	255 (change of state)
	3	inhibit time	0
	4	not used	-
1A00 h	0	number of mapped objects	1
	1	Status word	60410010 h

6th transmit PDO

Index	Subindex	Comment	Default Value
1805 h	0	number of entries	3
	1	COB-ID used by PDO	280h + node -ID
	2	transmission type	255
	3	inhibit time	0
	4	not used	-
1A05 h	0	number of mapped objects	2
	1	statusword	60400010 h
	2	vl_control_effort (RPM)	60440010 h

21st transmit PDO

Index	Subindex	Comment	Default Value
1814 h	0	number of entries	3
	1	COB-ID used by PDO	380h + node -ID
	2	transmission type	255
	3	inhibit time	0
	4	not used	-
1A14 h	0	number of mapped objects	4
	1	Status word	60400010 h
	2	vl_control_effort (RPM)	60440010 h
	3	process data word 0 from VLT 1051 index 0	h
	4	process data word 1 from VLT 1051 index 1	h

22nd transmit PDO

Index	Subindex	Comment	Default Value
1814 h	0	number of entries	3
	1	COB-ID used by PDO	480h + node -ID
	2	transmission type	255
	3	inhibit time	0
	4	not used	-
1A14 h	0	number of mapped objects	4
	1	process data word 2 from VLT 1051 index 2	h
	2	process data word 3 from VLT 1051 index 3	h
	3	process data word 4 from VLT 1051 index 4	h
	4	process data word 5 from VLT 1051 index 5	h

Danfoss Specific Objects (2000h-5FFFh)

CANopen index = DriveParameter + 2000h. Highest possible number 2EFFh. 2F00h+ is used for process data.

The drive parameters are converted as follows:

Drive Parameter	CANopen object index
1	2001h
2	2002h
...	...
7934	2EFFh

CANopen object index/sub-index	Contents	Parameter
2F00h/0	PCD 0 write	Par. 10-40 / 0
2F00h/1	PCD 1 write	Par. 10-40 / 1
2F00h/2	PCD 0 write	Par. 10-40 / 2
2F00h/3	PCD 0 write	Par. 10-40 / 3
2F00h/4	PCD 0 write	Par. 10-40 / 4
2F00h/5	PCD 0 write	Par. 10-40 / 5
2F10h/0	PCD 0 read	Par. 10-41 / 0
2F10h/1	PCD 1 read	Par. 10-41 / 1
2F10h/2	PCD 0 read	Par. 10-41 / 2
2F10h/3	PCD 1 read	Par. 10-41 / 3
2F10h/4	PCD 0 read	Par. 10-41 / 4
2F10h/5	PCD 1 read	Par. 10-41 / 5

How to Access FC 300 Parameters

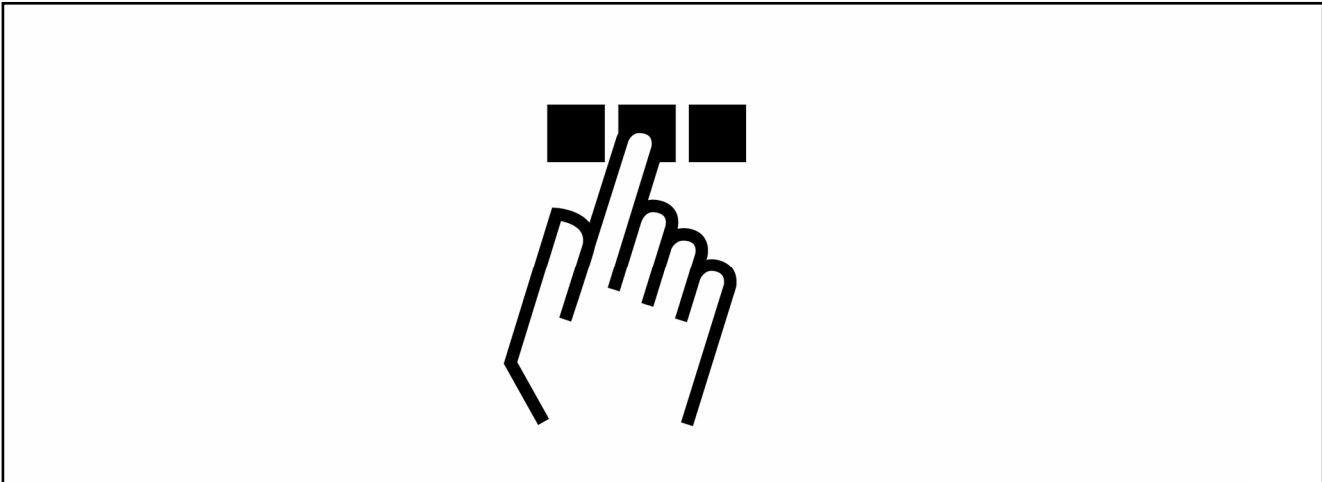

Service Data Objects (SDO)

FC 300 parameters can be accessed by Service Data Objects, SDOs. The SDOs are used for communicating non-time-critical data.

Structure of SDO COB-ID entry

bits	Unsigned32				LSB
	31	30	29	28-11	
11-bit-ID	0/1	0	0	0 0	10-0 11-bit Identifier
29-bit-ID	0/1	0	1	29-bit Identifier	

Description of SDO COB-ID entry

Bit number	Value	Meaning
31(MSB)	0	SDO valid
	1	SDO not valid
30	0	Reserved (always 0)
29	0	11-bit ID (CAN 2.0A)
	1	29-bit ID (CAN 2.0B)
28-11	0	If bit 29=0
	X	If bit 29=1: bits 28-11 of 29-bit-COB-ID
10-0 (LSB)	X	Bits 10-0 of COB-ID

An SDO is only valid if both SDO-valid-bits are 0. Bit 29 may be static (not changeable) e.g. due to hardware restrictions.

The following attributes specify a SDO domain object:

- name: according to CMS naming conventions with <application-specific name> = "SDO_xxx" with "xxx" as the number of the SDO, starting with 001. xxx = 001 - 128 for Server SDOs, 129 - 256 for Client SDOs.
- user type: client or server (owner of accessed object dictionary = server)
- class: Multiplexed Domain
- priority: application specific, suggested between [6,7]
- mux data type: STRUCTURE OF UNSIGNED (16) index, UNSIGNED (8) sub-index with "index" specifying an entry of the device object dictionary and "sub-index" specifying a component of a device object dictionary entry

Four different routines exist for uploading or downloading SDO data:

- Initiate download
- Download segment
- Initiate upload
- Upload segment

Initiate download

The initiate download starts the SDO communication from the client to the server.

Client request:

0 Byte					1		4		8
7..5 ccs	4 x	3,2 n	1 e	0 s	m index, sub index		d data		

Server response:

0 Byte					1		4		8
7..5 scs	4 ..0 x		m index, sub index		reserved				

Byte 0					Bytes 4-7
Bit 5-7	Bit 4	Bit 2,3	Bit 1	Bit 0	
ccs / scs	X	n	e	s	data
0: -	0	0: all data valid (size 4 byte)	0	0	reserved
1: init. Download request ccs	0	1: byte 7 no data (size 3 byte)	0	1	numbers of bytes for download
2: -	0	2: byte 6 - 7 no data (size 2 byte)	1	0	numbers of unspecified. bytes for download
3: init. Download response scs	0	3: byte 5 - 7 no data (size 1 byte)	1	1	data, length 4-n

Download segment

The download segment command is used when more than 5 bytes will be downloaded.

Client request:

0 Byte					1	8
7..5 ccs	4 x	3,2,1 n	0 c	segment data		

Server response:

0 Byte					1	8
7..5 ccs	4 t	3..0 X		reserved		

t: toggle bit
c: indicator for more segments

Byte 0			
Bit 5-7	Bit 4	Bit 3..1	Bit 0
ccs / scs	t toggle	n	c
0: Download seg. request ccs	0: 1. Seg starts with 0	0: all data valid (size 7 byte)	0: more segments to be downloaded
1: Download seg. response scs		1: byte 7 no data (size 6 byte)	0: no more segments to be downloaded
2: -		...	
3: -		7: byte 2 - 7 no data (size 1 byte)	

Initiate upload

The initiate upload starts the SDO communication from the client to the server.

Client request:

0 Byte				1	4	8
7..5 ccs	4 ..0 x		m index, sub index	reserved		

Server response:

0 Byte					1	4	8
7..5 ccs	4 x	3,2 n	1 e	0 s	m index, sub index	d data	

Byte 0					Bytes 4-7
Bit 5-7	Bit 4	Bit 2,3	Bit 1	Bit 0	
ccs / scs	X	n	e	s	data
0: -	0	0: all data valid (size 4 byte)	0	0	reserved
1: -	0	1: byte 7 no data (size 3 byte)	0	1	numbers of bytes for upload
2: init. upload request ccs / scs	0	2: byte 6 - 7 no data (size 2 byte)	1	0	numbers of unspecified Bytes for upload
3: -	0	3: byte 5 - 7 no data (size 1 byte)	1	1	data, length 4-n

Upload segment

The upload segment command is used when more than 5 bytes will be uploaded.

Client request:

0 Byte				1	8
7..5 ccs	4 t	3..0 X	reserved		

Server response:

0 Byte				1	8
7..5 ccs	4 x	3,2,1 n	0 c	segment data	

t: toggle bit

c: indicator for more segments

Byte 0			
Bit 5-7	Bit 4	Bit 3..1	Bit 0
ccs / scs	t toggle	n	c
0: Upload seg. Response scs	0: 1. Seg starts with 0	0: all data valid (size 7 byte)	0: more segments to be uploaded
1: -		1: byte 7 no data (size 6 byte)	0: no more segments to be uploaded
2: -		...	
3: Upload seg. Request ccs		7: byte 2 - 7 no data (size 1 byte)	

Example: Initiate Upload (read data)

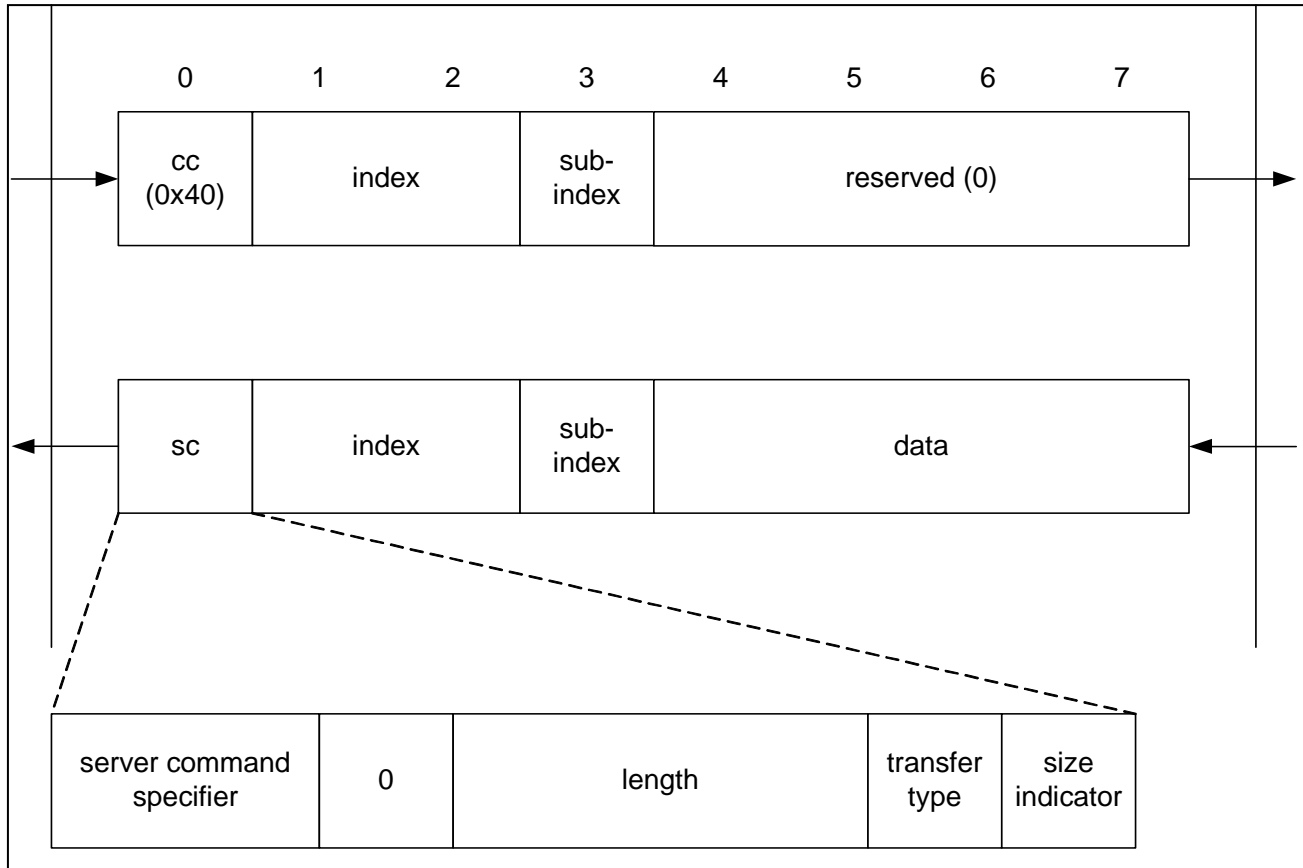

If the transfer type is set to 1, the reply consists only of 1 telegram ("expedited transfer"), i.e. the amount of transferred data is 0..4 bytes.

If the size indicator is set to 1, and the expedited bit is set, the length field contains the amount of data, that must be ignored, i.e., if the length is marked with "2", only the last 2 bytes (6 & 7) of the 8 byte telegram contain relevant data, the other 2 (4 & 5) may contain any (useless) data. Data is left aligned.

SDO Abort Code

The abort code describes the error code when an SDO generates a failure.

Abort Code	Description
0503 0000h	Toggle bit not alternated.
0504 0000h	SDO protocol timed out.
0504 0001h	Client/server command specifier not valid or unknown.
0504 0002h	Invalid block size (block mode only).
0504 0003h	Invalid sequence number (block mode only).
0504 0004h	CRC error (block mode only).
0504 0005h	Out of memory.
0601 0000h	Unsupported access to an object.
0601 0001h	Attempt to read a write only object.
0601 0002h	Attempt to write a read only object.
0602 0000h	Object does not exist in the object dictionary.
0604 0041h	Object cannot be mapped to the PDO.
0604 0042h	The number and length of the objects to be mapped would exceed PDO length.
0604 0043h	General parameter incompatibility reason.
0604 0047h	General internal incompatibility in the device.
0606 0000h	Access failed due to an hardware error.
0607 0010h	Data type does not match, length of service parameter does not match
0607 0012h	Data type does not match, length of service parameter too high
0607 0013h	Data type does not match, length of service parameter too low
0609 0011h	Sub-index does not exist.
0609 0030h	Value range of parameter exceeded (only for write access).
0609 0031h	Value of parameter written too high.
0609 0032h	Value of parameter written too low.
0609 0036h	Maximum value is less than minimum value.
0800 0000h	general error
0800 0020h	Data cannot be transferred or stored to the application.
0800 0021h	Data cannot be transferred or stored to the application because of local control.
0800 0022h	Data cannot be transferred or stored to the application because of the present device state.
0800 0023h	Object dictionary dynamic generation fails or no object dictionary is present (e.g. object dictionary is generated from file and generation fails because of an file error).

Parameters

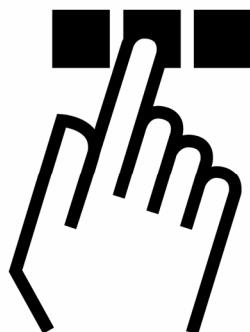

8-01 Control Site

Option:

*Digital and ctrl. word	[0]
Digital only	[1]
Control word only	[2]

Function:

Specifies the control as either *Digital* inputs, *Control* word or both. This parameter overrules the settings in par. 8-50 to 8-56.

8-02 Control Word Source

Option:

None	[0]
*FC RS485	[1]
FC USB	[2]
Option A	[3]
Option B	[4]
Option C0	[5]
Option C1	[6]

Function:

Specifies the source of the control word, serial interface or installed option. During initial power-up, the FC 300 automatically sets this parameter to *Option A* if it detects a valid bus option installed in this slot. If the option is removed, the frequency converter detects a change in the configuration and sets par. 8-02 back to the default setting *FC RS485*. The frequency converter trips. If an option is installed after initial power-up, the setting of par. 8-02 does not change, but the drive will be tripped and display: Alarm 67 *Option changed*.
Par. 8-02 cannot be changed while the motor is running.

8-03 Control Word Timeout Time

Range:

0.1 - 18000.0 s
* 1.0 s

Function:

Sets the maximum time allowed to pass between the reception of two consecutive telegrams. If this time is exceeded, it indicates that the serial communication has stopped. The function selected in par. 8-04 will then be carried out.

8-04 Control Word Timeout Function

Option:

*Off	[0]
Freeze Output	[1]
Stop	[2]
Jogging	[3]
Max. Speed	[4]
Stop and trip	[5]
Select set-up 1	[7]
Select set-up 2	[8]
Select set-up 3	[9]
Select set-up 4	[10]

Function:

A valid control word triggers the time-out counter. Acyclic DP V1 does not trigger the time-out counter. The *time-out* function is activated if the control word is not updated within the time specified in par. 8-03 *Control Word Timeout Time*.

- *Off*: Control via serial bus (Fieldbus or standard) resumes and uses the most recent control word.
- *Freeze output frequency*: Freeze output frequency until communication resumes.
- *Stop with auto restart*: Stop with auto restart when communication resumes.

- Parameters -

- *Output frequency = JOG freq.:* The motor runs at JOG frequency until communication resumes.
- *Output frequency = Max. freq.:* The motor runs at maximum frequency until communication resumes.
- *Stop with trip:* The motor stops. You need to reset the frequency converter, see explanation above.

Select set-up x:

This type of time-out function is used for changing set-up on a control word time-out. If communication resumes causing the time-out situation to disappear, par. 8-05 *End-of-time-out Function* defines whether to resume the set-up used before the time-out or to hold the set-up endorsed by the time-out function.

Note that the following parameters have to be configured for the set-up change to occur on a time-out. Par. 0-10 *Active set-up* has to be set to *Multi set-up* along with the relevant linking set in par. 0-12 *This Set-up Linked To*.

8-05 End-of-timeout Function

Option:

*Hold set-up	[0]
Resume set-up	[1]

Function:

Defines the action after receiving a valid control word upon a time-out. This only applies if set-up 1-4 has been selected in par. 8-04.

Hold: The drive holds the set-up selected in par. 8-04 and displays a warning, until par. 8-06 toggles. Then the drive resumes its original set-up.

Resume: The drive resumes the original set-up.

8-06 Reset Control Word Timeout

Option:

*Do not reset	[0]
Do reset	[1]

Function:

Used for returning the drive to the original set-up after a Control word timeout.

After setting the value to "Do Reset"[1], it returns to "Do not reset"[0].

8-07 DiagnosisTrigger

Option:

*Disable	[0]
Trigger on alarms	[1]
Trigger alarms/warn.	[2]

Function:

This parameter has no function for CANopen.

8-10 Control Word Profile

Option:

*FC profile	[0]
CANopen DSP 402	[5]

Function:

Selects the interpretation of the control and status words. The installed option in slot A determines the valid selection.

8-50 Coasting Select

Option:

Digital input	[0]
Bus	[1]
Logic AND	[2]
*Logic OR	[3]

Function:

Allows a choice between controlling the coasting function via the terminals (digital input) and/ or via the bus.



NB! This parameter is active only when par. 8-01 *Control site* is set to [0] *Digital and control word*.

8-51 Quick Stop Select

Option:

Digital input	[0]
Bus	[1]
Logic AND	[2]
*Logic OR	[3]

Function:

Allows a choice between controlling the Quick Stop function via the terminals (digital input) and/or via the bus.



NB! This parameter is active only when parameter 8-01 *Control site* is set to [0] *Digital and control word*.

8-52 DC brake select

Option:

Digital input	[0]
Bus	[1]
Logic AND	[2]
*Logic OR	[3]

Function:

Allows a choice between controlling the DC brake via the terminals (digital input) and/or via the bus.



NB! This parameter is active only when par. 8-01 *Control site* is set to [0] *Digital and control word*.

8-53 Start Select

Option:

Digital input	[0]
Bus	[1]
Logic AND	[2]
*Logic OR	[3]

Function:

Choose between controlling the drive via the terminals (digital input) and/or via the bus. If you select *Bus*, you can only activate the Start command if it is transmitted via the serial communication port or fieldbus option. If you select *Logic AND*, you must also activate the command via one of the digital inputs. If you select *Logic OR*, you can also activate the Start command via one of the digital inputs.

NB! This parameter is active only when par. 8-01 *Control site* is set to [0] *Digital and control word*.

8-54 Reversing Select

Option:

Digital input	[0]
Bus	[1]
Logic AND	[2]
*Logic OR	[3]

Function:

Choose between controlling the drive via the terminals (digital input) and/or via the bus. If you select *Bus*, you can only activate the Reversing command if it is transmitted via the serial communication port or fieldbus option. If you select *Logic AND*, you must also activate the command via one of the digital inputs. If you select *Logic OR*, you can also activate the Reversing command via one of the digital inputs.

NB! This parameter is active only when par. 8-01 *Control site* is set to [0] *Digital and control word*.

8-55 Set-up Select

Option:

Digital input	[0]
Bus	[1]
Logic AND	[2]
*Logic OR	[3]

Function:

Choose between controlling the drive via the terminals (digital input) and/or via the bus. If you select *Bus*, you can only activate Selection of Setup if it is transmitted via the serial communication port or fieldbus option. If you select *Logic AND*, you must also activate the command via one of the digital inputs. If you select *Logic OR*, you can also activate the Set-up command via one of the digital inputs.

NB! This parameter is active only when par. 8-01 *Control site* is set to [0] *Digital and control word*.

8-56 Preset Reference Select

Option:

Digital input	[0]
Bus	[1]
Logic AND	[2]
*Logic OR	[3]

Function:

Choose between controlling the drive via the terminals (digital input) and/or via the bus. If you select *Bus*, you can only activate the Preset Reference command if it is transmitted via the serial communication port or fieldbus option. If you select *Logic AND*, you must also activate the command via one of the digital inputs. If you select *Logic OR*, you can also activate the Preset Reference command via one of the digital inputs.

NB! This parameter is active only when par. 8-01 *Control site* is set to [0] *Digital and control word*.

8-90 Bus Jog 1 Speed

Option:

0 – par. 4-13 RPM * 100 RPM

Function:

Sets a fixed speed (jog) activated via the serial port or bus option.

8-91 Bus Jog 2 Speed

Option:

0 – par. 4-13 RPM * 200 RPM

Function:

Sets a fixed speed (jog) activated via the serial port or bus option.

10-00 CAN Protocol

Option:

Read only from LCP.
*CANopen [0]

Function:

Indicates the CAN protocol.

- Parameters -

10-01 Baud rate select

Option:

10 kbps	[16]
20 kbps	[17]
50 kbps	[18]
100 kbps	[19]
*125 kbps	[20]
250 kbps	[21]
500 kbps	[22]
500 kbps	[23]
1000 kbps	[24]

Function:
Selection of the CANopen transmission speed. The selection must correspond to the transmission speed of the master and the other CANopen nodes.

10-02 Drive Node ID

Range:

Bus Address 0 - 127	* 127
---------------------	-------

Function:
Selection of station address. Every station connected to the same CANopen network must have an unambiguous address.

10-05 Readout Transmit Error Counter

Range:

0 - 255	* 0
---------	-----

Function:
Displays the Transmit Error Counter of the CAN controller since the last power-up.

10-06 Readout Receive Error Counter

Range:

0 - 255	* 0
---------	-----

Function:
Displays the Receive Error Counter of the CAN controller since the last power-up.

10-07 Readout Bus Off Counter

Range:

0 - 255	* 0
---------	-----

Function:
Displays the number of Bus Off events since the last power-up.

10-31 Store Data Values

Option:

*Off	[0]
Store edit set-up	[1]
Store all set-ups	[2]

Function:
Par. 10-31 is used to activate storing of data in non-volatile memory.

10-32 CANopen Revision

Range:

0 - 65535 N/A	* 0 N/A
---------------	---------

Function:
Par. 10-32 is used for EDS file creation.

10-33 Store Always

Option:

*Off	[0]
On	[1]

Function:
This parameter is used to select whether parameter data received via the CANopen option should be stored in EEPROM as default.

10-50 CANopen Process Data Config. Write

Option:

*0 None	[0]
16-80 Fieldbus CTW 1	[1]
16-82 Fieldbus REF 1	[2]
3-02 Minimum reference	[3]
3-03 Maximum reference	[4]
3-12 Catch up/slow down value	[5]
3-41 Ramp 1 ramp up time	[6]
3-42 Ramp 1 ramp down time	[7]
3-51 Ramp 2 ramp up time	[8]
3-52 Ramp 2 ramp down time	[9]
3-80 Jog ramp time	[10]
3-81 Quick stop ramp time	[11]
4-11 Motor speed low limit (RPM)	[12]
4-13 Motor speed high limit (RPM)	[13]
4-16 Torque limit motor mode	[14]
4-17 Torque limit generator mode	[15]
8-90 Bus Jog 1 Speed	[16]
8-91 Bus Jog 2 Speed	[17]

Function:
Only elements [2] and [3] of this array can be selected ([0] and [1] are fixed).

10-51 CANopen Process Data Config. Read

Option:

- *0 None
- 16-03 Status word
- 16-05 Main actual value (%)
- 16-00 Control Word
- 16-01 Reference (Unit)
- 16-02 Reference %
- 16-04 Main actual value (Unit)
- 16-91 Alarm word 2
- 16-92 Warning word
- 16-90 Alarm word
- 16-93 Warning word 2
- 16-94 Ext. status word
- 16-95 Ext. status word 2
- 16-10 Power (kW)
- 16-11 Power (hp)
- 16-12 Motor voltage
- 16-13 Frequency
- 16-14 Motor current
- 16-16 Torque
- 16-17 Speed (RPM)
- 16-18 Motor thermal
- 16-19 KTY sensor temperature
- 16-20 Phase angle
- 16-30 DC link Voltage
- 16-32 Brake energy/s
- 16-33 Brake energy/2 min
- 16-34 Heatsink temp.
- 16-35 Inverter thermal
- 16-38 SL controller state
- 16-39 Controlcard temp.
- 16-50 External reference
- 16-51 Pulse reference
- 16-52 Feedback (Unit)
- 16-53 Digi pot reference
- 16-60 Digital input
- 16-61 Terminal 53 switch setting
- 16-62 Analog input 53
- 16-63 Terminal 54 switch setting
- 16-64 Analog input 54
- 16-65 Analog output 42 (mA)
- 16-66 Digital output (bin)
- 16-67 Freq. input #29 (Hz)
- 16-68 Freq. input #33 (Hz)
- 16-69 Pulse output #27 (Hz)
- 16-70 Pulse output #29 (Hz)
- 16-84 Comm. option STW
- 16-85 FC port CTW 1
- 16-09 Custom readout

Function:

Only elements [2] and [3] of this array can be selected ([0] and [1] are fixed).

15-60 Option mounted

Option:

Read only from LCP.
* CANopen

Function:

Shows the option type installed.

16-48 Com Option STW

Option:

Function:

Bit:	Meaning:
0	COB RX overflow in interrupt handler, messages lost
1	CAN overrun indicated by CAN controller
2	CAN bus off
3	Controller status bit set
4	Controller status bit reset
5	Low priority tx queue full
7	Rx queue full

16-90 Alarm Word

Range:

0 - FFFF
* 0

Function:

Returns the alarm word sent via the serial communication port in hex code.

16-92 Warning Word

Range:

0 - FFFF
* 0

Function:

Returns the warning word sent via the serial communication port in hex code.

Parameter List

PNU #	Parameter Designation	Default value	Range	Conversion index	Data type
8-01	Control Site	Dig. and ctrl. word [0]	[0 - 2]	-	5
8-02	Control Word Source	FC RS485 [1]	[0 - 6]	-	5
8-03	Control Word Timeout Time	1.0 s	0.1 - 18000	-1	7
8-04	Control Word Timeout Function	Off [0]	[0 - 10]	-	5
8-05	End-of-timeout Function	Hold set-up [0]	[0 - 1]	-	5
8-06	Reset Control Word Timeout	Do not reset [0]	[0 - 1]	-	5
8-07	Diagnosis Trigger	Disable [0]	[0 - 3]	-	5
8-10	Control Word Profile	FC profile [0]	[0 - x]	-	5
8-50	Coasting Select	Logic OR [3]	[0 - 3]	-	5
8-51	Quick Stop Select	Logic OR [3]	[0 - 3]	-	5
8-52	DC Brake Select	Logic OR [3]	[0 - 3]	-	5
8-53	Start Select	Logic OR [3]	[0 - 3]	-	5
8-54	Reversing Select	Logic OR [3]	[0 - 3]	-	5
8-55	Set-up Select	Logic OR [3]	[0 - 3]	-	5
8-56	Preset Reference Select	Logic OR [3]	[0 - 3]	-	5
8-90	Bus Jog 1 Speed	100 rpm	0 - par.4-13	67	6
8-91	Bus Jog 2 Speed	200 rpm	0 - par.4-13	67	6
10-00	CAN Protocol	CANopen [0]	[0]	-	5
10-01	Baud Rate Select	125 Kbps [20]	[16 - 22]	-	5
10-02	Drive Node ID	127	0 - 127	0	5
10-05	Readout Transmit Error Counter	0	0 - 255	0	5
10-06	Readout Receive Error Counter	0	0 - 255	0	5
10-07	Readout Bus Off Counter	0	0 - 255	0	6
10-31	Store Data Values	Off [0]	[0 - 2]	-	5
10-32	CANopen revision	0	0 - 65535	-	6
10-33	Store Always	Off [0]	[0 - 1]	-	5
10-40	CANopen Process Data Config. Write	None [0]	[0 - 17]		
10-41	CANopen Process Data Config. Read	None [0]	[0 - 48]		
15-60	Option Mounted	CANopen			
16-48	Com Option STW		[0 - 7]		
16-90	Alarm Word	0	0 - FFFF	0	7
16-92	Warning Word	0	0 - FFFF	0	7

Data Types Supported by FC 300

Object and Data Types Supported by FC 300

Data types supported by FC 300

Data type	Description
3	Integer 16
4	Integer 32
5	Unsigned 8
6	Unsigned 16
7	Unsigned 32
9	Visible string
10	Byte string
33	Standardized value (16 bit)
35	Bit sequence
41	Byte
42	Word

Conversion index

This number refers to a conversion figure used when writing or reading to parameters.

Conversion index	Conversion factor
100	1
67	1/60
6	1000000
5	100000
4	10000
3	1000
2	100
1	10
0	1
-1	0.1
-2	0.01
-3	0.001
-4	0.0001
-5	0.00001
-6	0.000001

Troubleshooting

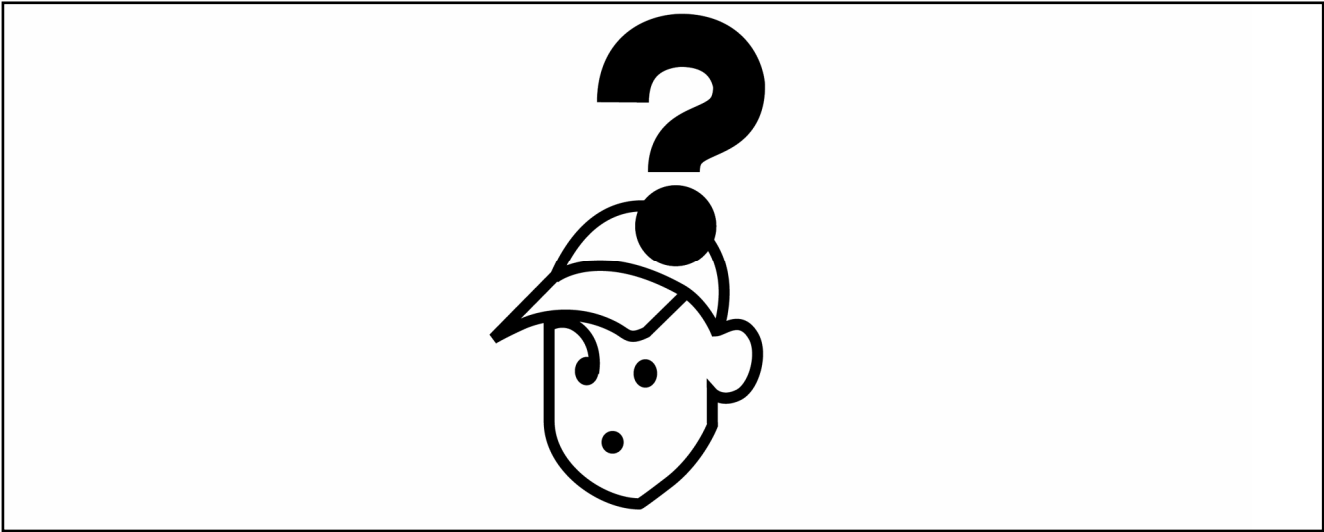

Troubleshooting

LED Status

First, check the LEDs.

The CANopen control card contains two bi-colour (green/red) LEDs to indicate the state of the device and the network respectively.

The upper LED (Error LED) indicates module status (MS).

The lower LED (Run LED) indicates network status (NS).

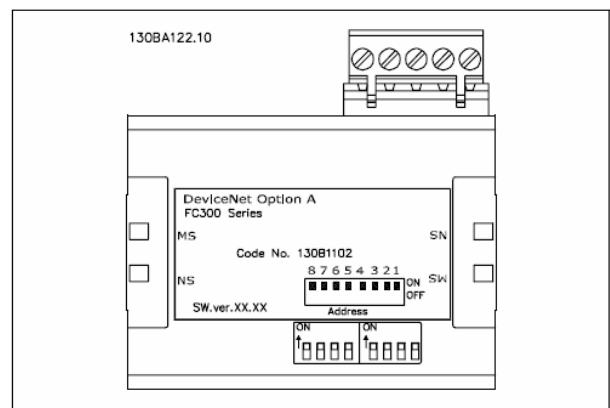

- Troubleshooting -

Error LED / Module Status (MS) LED, red

No	LED state	device state	description
1	Off	no error	no error
2	single flash	warning limit reached	CAN error counter(s) has reached / exceeded warning level
3	Flickering	autobaud	autobaud in progress
4	double flash	error control event	guard event (NMT slave) or heartbeat event (heartbeat consumer) has occurred
5	triple flash	sync error	sync message has not been received within configured timeout (object 0x1006)
6	On	bus off	bus off

If more than 1 error has occurred, the one with the highest number will be displayed.

Run LED / Network Status (NS) LED, green

No	LED state	Device state	Description
1	flickering	Auto Baud	auto baud active
2	single flash	stopped	device is in stopped state
3	blinking	pre-operational	device is in pre-operational state
4	on	operational	device is in operational state

Other states

State	MS LED	NS LED
COP initialize error	solid red	solid red
wait for AOC	red/green blinking	red/green blinking

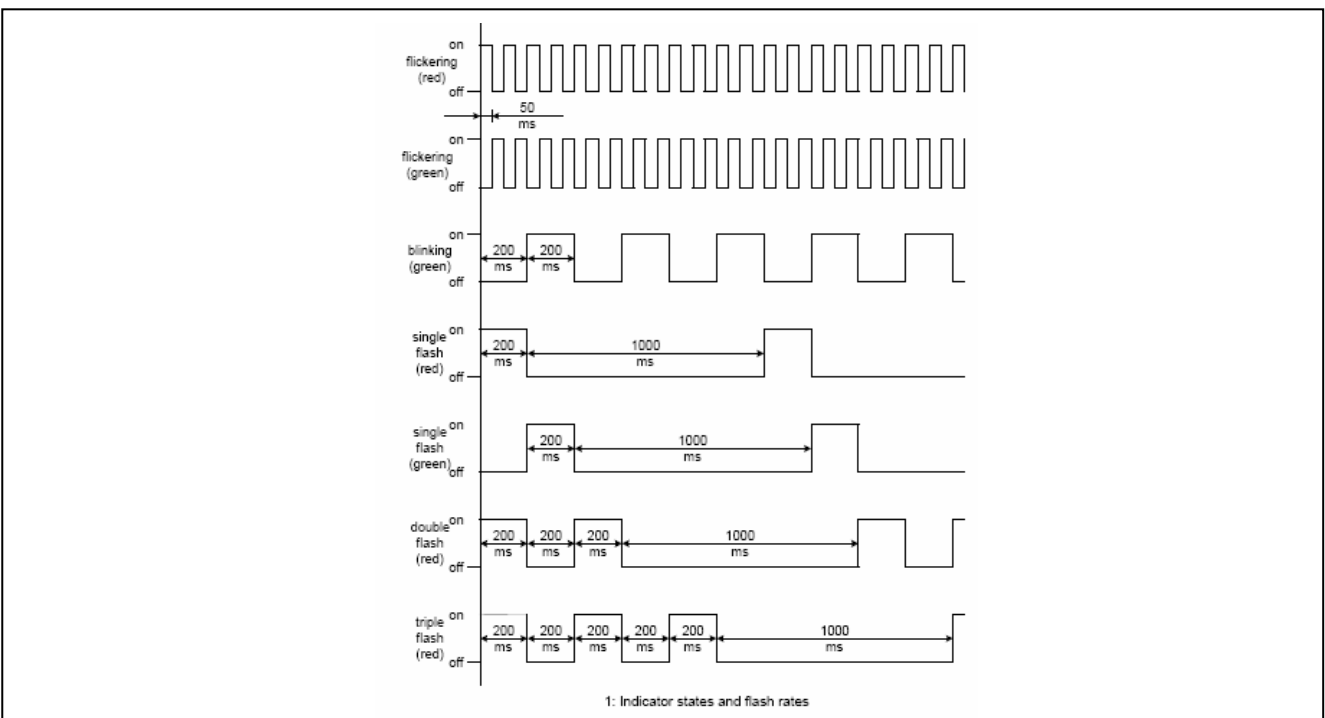

No Communication with the Drive

If there is no communication with the drive, proceed with the following checks:

Check 1: Is the cabling correct?

Check that the cables are connected to the correct terminals as shown in the diagram.

Pin no.	Terminal	Colour	Name
1	-	-	Reserved
2	CAN_L	Blue	CAN LOW
3	Drain	(bare)	Screen
4	CAN_H	White	CAN HIGH
5	-	-	Reserved

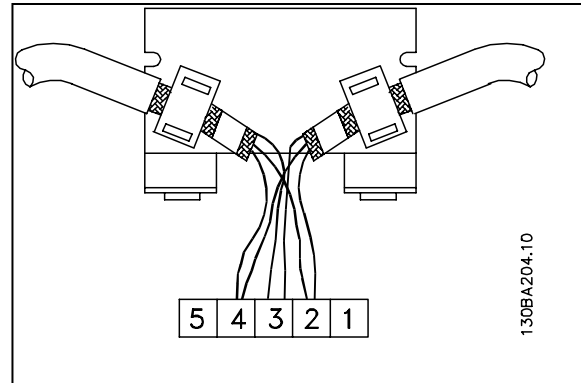

Check 2: Is the correct EDS file installed?

Download the correct EDS file from <http://www.danfoss.com/drives>.

Check 3: Is the bus connection terminated at both ends?

If not, terminate the bus connection with termination resistors at the initial and final nodes, as shown in the following diagram. Termination is performed between terminal 2 (CAN_L) and 4 (CAN_H) with a resistor: 121 Ohm, 1% metal film, ¼ Watt.

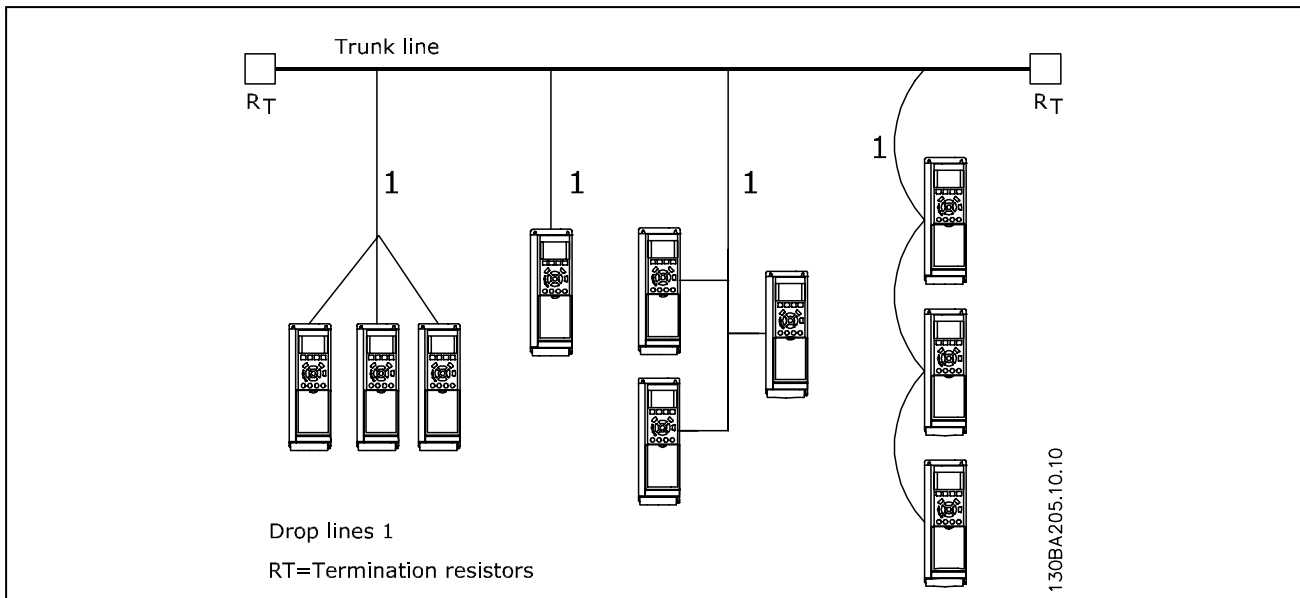

- T r o u b l e s h o o t i n g -

Drive Will Not Respond to Control Signals

- Danfoss Control Word profile

Check 1: Is the Control word valid?

If bit 10=0 in the Control word, then the drive will not accept the Control word, because the default setting is bit 10=1. Set bit 10=1 via the PLC.

Check 2: Is the relationship between bits in the Control word and the terminal I/Os correct?

Check the logical relationship in the frequency converter.

Set the logic to bit 3=1 AND digital input=1 in order to achieve a successful start.

Define the desired logical relationship in par. 8-50 to 8-56 according to the following range of options. Select the FC 300 control mode, digital input and/or bus communication, using par. 8-50 to 8-56.

The tables below show the effect upon the FC 300 of a coast command for the full range of par. 8-50 settings.

The effect of control mode upon the function of par. 8-50 *Coasting select*, 8-51 *Quick stop select* and 8-52 *DC Brake select* is as follows:

If *Digital input* [0] is selected, the terminal will control the Coast and DC Brake functions.

Par. 8-50/51/52 setting: Digital input [0]		
Terminal	Bit 02/03/04	Function
0	0	Coast/DC brake/Q-Stop
0	1	Coast/DC brake/Q-Stop
1	0	No Coast/DC brake/Q-Stop
1	1	No Coast/DC brake/Q-Stop

If *Bus* [1] is selected, commands will be activated only when given via the control word.

Par. 8-50/51/52 setting: Bus [1]		
Terminal	Bit 02/03/04	Function
0	0	Coast/DC brake/Q-Stop
0	1	No Coast/DC brake/Q-Stop
1	0	Coast/DC brake/Q-Stop
1	1	No Coast/DC brake/Q-Stop

If *Logic AND* [2] is selected, both signals must be activated to perform the function.

Par. 8-50/51/52 setting: Logic AND [2]		
Terminal	Bit 02/03/04	Function
0	0	Coast/DC brake/Q-Stop
0	1	No Coast/DC brake/Q-Stop
1	0	No Coast/DC brake/Q-Stop
1	1	No Coast/DC brake/Q-Stop

If *Logic OR* [3] is selected, activation of one signal will activate the function.

Par. 8-50/51/52 setting: Logic OR [3]		
Terminal	Bit 02/03/04	Function
0	0	Coast/DC brake/Q-Stop
0	1	Coast/DC brake/Q-Stop
1	0	Coast/DC brake/Q-Stop
1	1	No Coast/DC brake/Q-Stop



NB!:

Please note that Coasting, Quick Stop and DC brake functions are active for logic "0".

The effect of control mode upon the function of par. 8-53 *Start select* and 8-54 *Reversing select*:

If *Digital input* [0] is selected, the terminals will control the start and reversing functions

Par. 8-53/54 setting: Digital input [0]		
Terminal	Bit 06/15	Function
0	0	Stop/Anti-clockwise
0	1	Stop/Anti-clockwise
1	0	Start/Clockwise
1	1	Start/Clockwise

If *Bus* [1] is selected, commands will be activated only when given via the control word.

Par. 8-53/54 setting: Bus [1]		
Terminal	Bit 02/03/04	Function
0	0	Stop/Anti-clockwise
0	1	Start/Clockwise
1	0	Stop/Anti-clockwise
1	1	Start/Clockwise

If *Logic AND* [2] is selected, both signals must be activated to perform the function.

Par. 8-53/54 setting: Logic AND [2]		
Terminal	Bit 02/03/04	Function
0	0	Stop/Anti-clockwise
0	1	Stop/Anti-clockwise
1	0	Stop/Anti-clockwise
1	1	Start/Clockwise

If *Logic OR* [3] is selected, activation of one signal will activate the function.

Par. 8-53/54 setting: Logic OR [3]		
Terminal	Bit 02/03/04	Function
0	0	Stop/Anti-clockwise
0	1	Start/Clockwise
1	0	Start/Clockwise
1	1	Start/Clockwise

- T r o u b l e s h o o t i n g -

The effect of control mode upon the function of par. 8-55 *Set-up select* and 8-56 *Preset reference select*:

If *Digital input* [0] is selected, the terminals will control the set-up and preset reference functions.

Par. 8-55/56 setting: Digital input [0]				
Terminal		Bit 00/01, 13/14		Function
Msb	Lsb	Msb	Lsb	Preset ref., Set-up no.
0	0	0	0	1
0	0	0	1	1
0	0	1	0	1
0	0	1	1	1
0	1	0	0	2
0	1	0	1	2
0	1	1	0	2
0	1	1	1	2
1	0	0	0	3
1	0	0	1	3
1	0	1	0	3
1	0	1	1	3
1	1	0	0	4
1	1	0	1	4
1	1	1	0	4
1	1	1	1	4

If *Bus* [1] is selected, commands will be activated only when given via the control word.

Par. 8-55/56 setting: Bus [1]				
Terminal		Bit 00/01, 13/14		Function
Msb	Lsb	Msb	Lsb	Preset ref., Set-up no.
0	0	0	0	1
0	0	0	1	2
0	0	1	0	3
0	0	1	1	4
0	1	0	0	1
0	1	0	1	2
0	1	1	0	3
0	1	1	1	4
1	0	0	0	1
1	0	0	1	2
1	0	1	0	3
1	0	1	1	4
1	1	0	0	1
1	1	0	1	2
1	1	1	0	3
1	1	1	1	4

If *Logic AND* [2] is selected, both signals must be activated to perform the function.

Par. 8-55/56 setting: Logic AND [2]				
Terminal		Bit 00/01, 13/14		Function
Msb	Lsb	Msb	Lsb	Preset ref., Set-up no.
0	0	0	0	1
0	0	0	1	1
0	0	1	0	1
0	0	1	1	1
0	1	0	0	1
0	1	0	1	2
0	1	1	0	1
0	1	1	1	2
1	0	0	0	1
1	0	0	1	1
1	0	1	0	3
1	0	1	1	3
1	1	0	0	1
1	1	0	1	2
1	1	1	0	3
1	1	1	1	4

If *Logic OR* [3] is selected, activation of one signal will activate the function.

Par. 8-55/56 setting: Logic OR [3]				
Terminal		Bit 00/01, 13/14		Function
Msb	Lsb	Msb	Lsb	Preset ref., Set-up no.
0	0	0	0	1
0	0	0	1	2
0	0	1	0	3
0	0	1	1	4
0	1	0	0	2
0	1	0	1	2
0	1	1	0	4
0	1	1	1	4
1	0	0	0	3
1	0	0	1	4
1	0	1	0	3
1	0	1	1	4
1	1	0	0	4
1	1	0	1	4
1	1	1	0	4

- T r o u b l e s h o o t i n g -

Alarm Word and Warning Word

Alarm word and warning word are shown on the display in Hex format. If there is more than one warning or alarm, a sum of all warnings or alarms will be shown. Warning word and alarm word can also be displayed using the field bus in par. 16-05,-16-06 and 16-04.

FC 300				
Bit (Hex)	Alarm word (Par. 16-90)	Alarm no.	Major / minor alarm	Recoverable / unrecoverable alarm
00000001	Unused	-	-	-
00000002	Drive over temperature	29	Major	Recoverable
00000004	Earth fault	14	Major	Unrecoverable
00000008	Unused	-	-	-
00000010	Control word timeout	18	Minor	Recoverable
00000020	Over current	13	Major	Unrecoverable
00000040	Torque limit	12	Major	Recoverable
00000080	Motor thermistor over temp.	11	Major	Recoverable
00000100	Motor ETR over temperature	10	Major	Recoverable
00000200	Inverter overloaded	9	Major	Recoverable
00000400	DC link under voltage	8	Major	Recoverable
00000800	DC link over voltage	7	Major	Recoverable
00001000	Short circuit	16	Major	Unrecoverable
00002000	Inrush fault	33	Major	Recoverable
00004000	Mains phase loss	4	Major	Unrecoverable
00008000	AMA not OK	50	Minor	Recoverable
00010000	Live zero error	2	Major	Recoverable
00020000	Internal fault	38	Major	Unrecoverable
00040000	Brake resistor power limit	26	Major	Unrecoverable
00080000	Motor phase U is missing	30	Major	Unrecoverable
00100000	Motor phase V is missing	31	Major	Unrecoverable
00200000	Motor phase W is missing	32	Major	Unrecoverable
00400000	Fieldbus comm. fault	34	Major	Recoverable
00800000	24V supply fault	47	Major	Unrecoverable
01000000	Mains failure	36	Major	Recoverable
02000000	1.8V supply fault	48	Major	Unrecoverable
04000000	Brake resistor short circuit	25	Major	Recoverable
08000000	Brake chopper fault	27	Major	Recoverable
10000000	Unused	-	-	-
20000000	Unused	-	-	-
40000000	Unused	-	-	-
80000000	Unused	-	-	-

FC 300		
Bit (Hex)	Warning word (Par 16-92)	Warning no.
00000001	Unused	-
00000002	Drive over temperature	29
00000004	Earth fault	14
00000008	Unused	-
00000010	Control word timeout	18
00000020	Over current	13
00000040	Torque limit	12
00000080	Motor thermistor over temp.	11
00000100	Motor ERT over temperature	10
00000200	Inverter overloaded	9
00000400	DC link under voltage	8
00000800	DC link over voltage	7
00001000	DC link voltage low	6
00002000	DC link voltage high	5
00004000	Mains phase loss	4
00008000	No motor	3
00010000	Live zero error	2
00020000	10V low	1
00040000	Brake resistor power limit	26
00080000	Brake resistor short circuit	25
00100000	Brake chopper fault	27
00200000	Speed limit	49
00400000	Fieldbus comm. fault	34
00800000	24V supply fault	47
01000000	Mains failure	36
02000000	Current limit	59
04000000	Unused	-
08000000	Unused	-
10000000	Unused	-
20000000	Unused	-
40000000	Unused	-
80000000	Warning word 2 (ext. stat. word)	-

Alarm / Warning Limits

Warning and Alarm Messages

There is a clear distinction between alarms and warnings. In the event of an alarm, The frequency converter will enter a fault condition. After the cause for the alarm has been cleared, the master will have to acknowledge the alarm message for the frequency converter to start operating again. A warning on the other hand may come when a warning condition appears, and disappear when conditions return to normal without interfering with the process.

Warnings

All warnings within the frequency converter are represented by a single bit within a warning word. A warning word is always an action parameter. Bit status FALSE [0] means no warning, while bit status TRUE [1] means warning. To each bit and each bit status there is a corresponding text string. In addition to the warning word message the master will also be notified through a change of bit 7 in the Status Word.

Alarms

Following an Alarm message, the frequency converter will enter Fault condition. Only after the fault has been alleviated and the master has acknowledged the alarm message by setting bit 3 in the Control Word, can the frequency converter resume operation. All alarms within the frequency converter are represented by a single bit within an alarm word. An alarm word is always an action parameter. Bit status FALSE [0] means no alarm, while bit status TRUE [1] means alarm.

Index

- A
 - Abbreviations
 - Alarm word
 - Alarms
- C
 - Cable lengths
 - Cable specifications
 - Connection of the cable screen
 - CANopen connection
 - CANopen object classes
 - CANopen termination
 - Conversion index
- D
 - Danfoss FC control profile
 - Danfoss object classes
 - Drive will not respond to control signals
 - Drop cable
- E
 - Earth connection
 - EDS file
 - EMC precautions
- I
- L
 - LED status
 - LEDs
- N
 - Network power consumption
 - No communication with the drive
- O
 - Object and data types supported by FC 300
- P
 - Polling
- S
 - Safety note
 - Setting the CANopen address
 - Setting the CANopen baud rate
- T
 - Topology
- V
 - VLT parameters
- W
 - Warning word
 - Warnings