

SECURITY BRAKES

For lifts, elevators,
hoists and other
machines

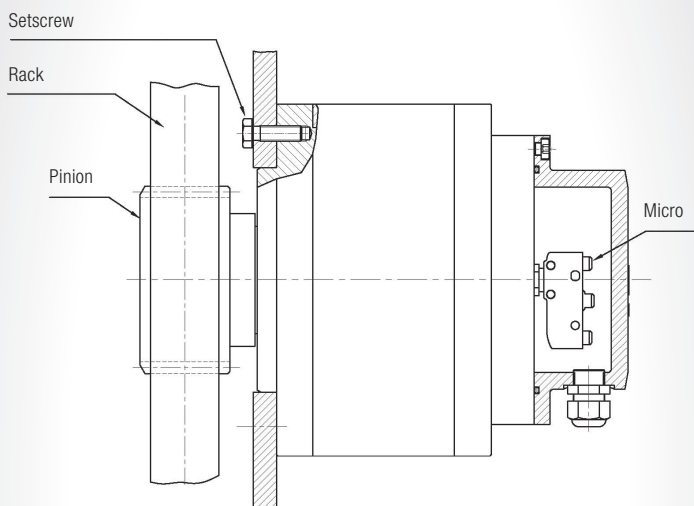

The unit **must be firmly attached to the platform structure** so that the sprocket is perfectly centered and in engagement with the rack. After mounting the unit, connect the cables to the micro connector. Typically, this is in closed position.

The long experience of our company in security requires us to the realization of the product.

The FPC brake is delivered **regulated according to the specific characteristics of the machine** on which it will be mounted. As ever this should be mounted on a different machine, its traceability must be ensured.

The parachute is sealed for safety, preventing the further handling.

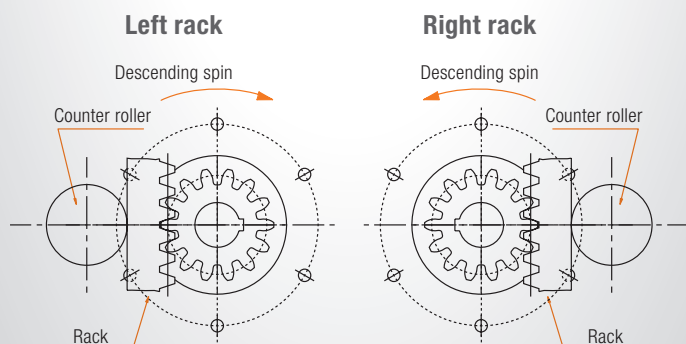

Type FPC
Automatic reset



Description

The FPC security brake is a mechanical unit **designed to prevent accidental falls** in lifting gear motorized by transmission sprockets or rack and pinion devices.

The system only operates when the descent rate exceeds a predetermined value. The sensor elements act by the action of centrifugal force and interlock the follower pinion against the structure of the elevator. The locking occurs **in a progressive way**. The platform is immobilized after being braked.

By actuating the mechanism in the opposite direction to interlock, the brake returns to its original state. For the proper operation of the machine it is essential to analyze the causes that triggered the security system and solve the problem.

These safety brakes incorporate a microswitch which operates in the interlocking. This signal can cut the general current of the elevator, activate an alarm, etc.

Features

FPC security brakes prevent accidental falls in all types of lifting devices (pinion-rack, drum-wire, etc.).

Compact and robust, they are particularly suitable for installation in wind tower elevators, cranes and other industrial applications.

The operation is **completely mechanical**. No force or external signal is required to work.

The system only operates when the descent rate exceeds a predetermined value. The braking starts immediately when the speed is surpassed, immobilizing the platform. **Braking occurs progressively**.

Automatic reset without manipulation backing to the point of origin

The system incorporates a protected inner microswitch which acts at locking. Thus, the signal used to cut the power, trigger an alarm, etc.

Blocking directions: clockwise, anticlockwise, and bidirectional.

Certified product according

to EN 12158, EN12159,
EN 1495, 95/16/CE and
ATEX 94/9/CE directives.



Electromagnetic, pneumatic brakes and clutches
Mechanical safety brakes · Centrifugal brakes
Flexible couplings · Torque limiters · Special units



SECURITY BRAKES

Type FPC

Automatic reset

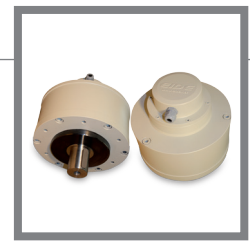

Sizes	FPC-500	FPC-1000	FPC-3500	FPC-6000
Locking speed	180-400 rpm	160-400 rpm	150-300 rpm	150-300 rpm
Couple	150-500 Nm	350-1250 Nm	900-3800 Nm	2000-7000 Nm

Examples of applications of FPC brakes to diverse systems (rack and pinion, drum-wire, balancing, etc.)

Also applies to overhead doors, counterweights, palletizers, strapping, squips, retractable baskets, baskets, shelves, etc.

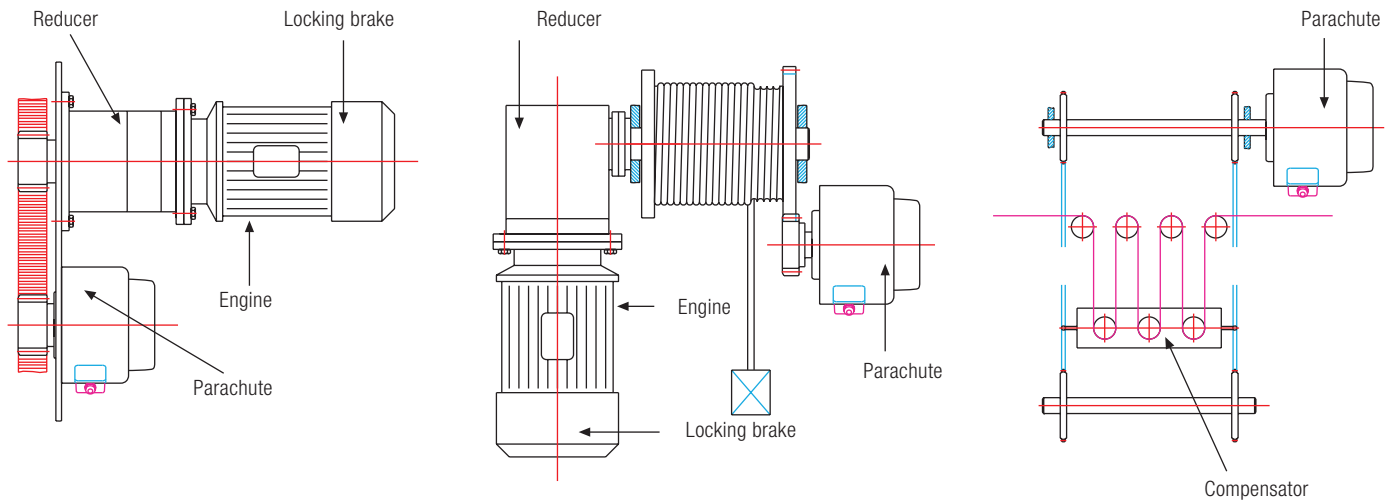

Versions

Unidirectional · Bidirectional · Double shaft · Special models.

Measurements

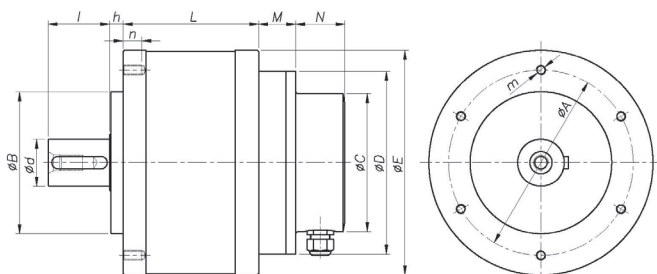

Sizes	FPC-500	FPC-1000	FPC-3500	FPC-6000
AØ	120	150	205	270
BØ	90	115	150	150
CØ	115	112	112	112
DØ	100	148	148	148
EØ	132	182	245	245
dø	28	38	50	60
Mxn	6 M8 x 15	6 M8 x 15	6 M10 x 19	12 Ø13 x 22.5
l	40	50	60	80
h	8	11	16	16
L	80	106	117	190
M	28	30	36	36
N	37	40	40	40